

## Exposed 1/2" Thermostatic Valve General Installation Instructions

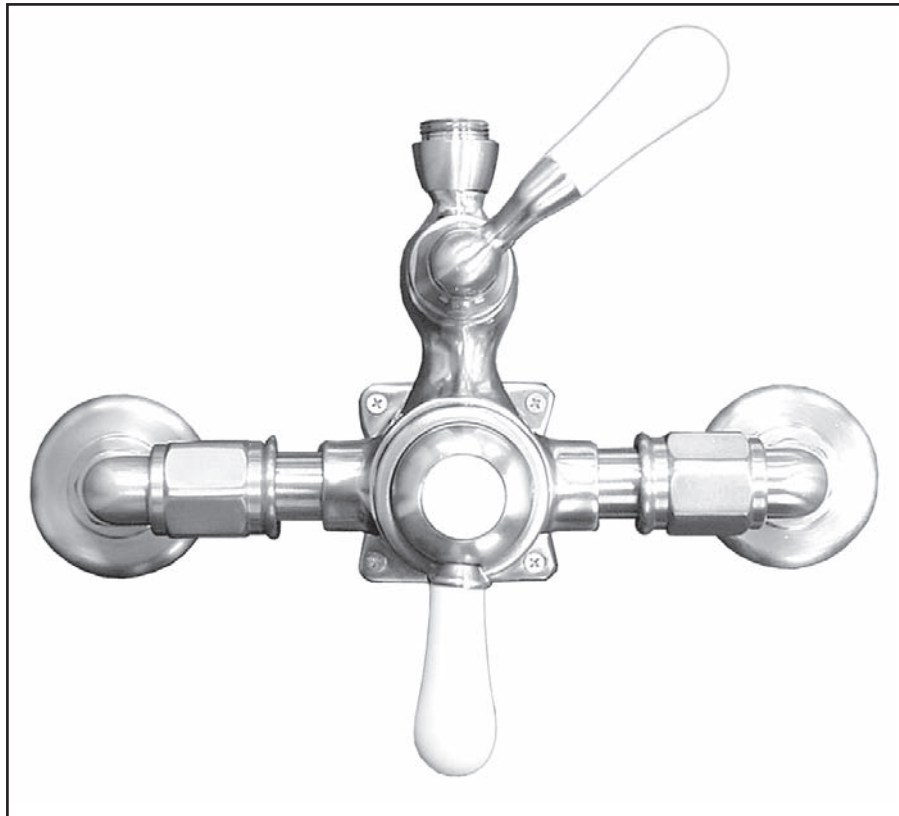

### LEAVE FOR HOME OWNER

#### Care Instructions:

The product you have just purchased is designed to provide you with long lasting beauty and dependability. To ensure your product's longevity, please follow the following care instructions.

When installing, we recommend you lay all parts on a soft cloth or towel to avoid scratching or damaging the product. To care for your fitting, wipe with a clean, soft, damp cloth and blot dry as often as possible. Never use abrasive cleansers, sponges, or acidic cleaning products as these may damage the finish and may VOID THE WARRANTY.

## Welcome to the World of Thermostatic Systems Both Exposed and Concealed Valves

Please read ALL instructions, cautions, and care recommendations before beginning installation.

These products comply with Section 9 of NSF 61 criteria concerning lead content.

### **! CAUTIONS !**

1. **APPLY NO HEAT/NO TORCH TO THE VALVE ASSEMBLY.**
2. Take special care to protect all components during the construction and installation.
3. Open all boxes carefully. The products are heavy and damage can occur after you open the contents.
4. We suggest all products be set on a soft work surface like an old blanket for review before installation. Cement floors are too hard.
5. Always turn off water at the source before beginning installation.
6. Go slowly - A cautious installation creates a beautiful finished result.
- Caution 7.** Use no pliers, vice grips or channel locks on this finished trim - you will scratch or mar the surface.
- Caution 8.** Use a crescent wrench on all nuts - be deliberate and patient - no damage will happen.
9. If you have the factory installation tool kit, follow the instructions enclosed.
10. Concealed thermostatic systems are the norm in the USA today. Valves are usually installed inside the frame construction and there is no danger from exposed pipes.
11. All of the Exposed Thermostatic Systems are state of the art and meet or exceed all codes for approved products in the USA and Canada.
12. All systems are fail safe and will not allow hot water to exceed 120 ° degrees Fahrenheit during any showering or bathing experience if properly installed.

13. Each individual bather can adjust the temperature at will while using the shower. Our thermostatic systems have separate temperature controls from the exit controls.
14. Exposed hot water pipes are potentially dangerous to the unsuspecting person. We are used to concealed plumbing pipes inside the walls of a typical home.
15. Be advised that exposed thermostatic systems have a **HOT** water line that can be too hot to touch! **Beware of burns!**
16. Exposed piping means you can touch the cold and hot water lines.
17. Exposed piping means you can see if anything is wrong with your plumbing.
18. Exposed piping means you can service your system easily.
19. Exposed piping means you don't have to remove your walls if a problem occurs.
20. We have labeled the hot side as a preliminary caution for the homeowner. Please leave the attached label in place for the homeowner to remove when the installation is complete.
21. **1/2" copper water lines are required for the hot and cold inlets.**
22. Remember the exposed piping is **not a grab bar** and we do not imply in any way that our installation procedures are for any other purpose than to support the exposed pipes on the prepared surfaces of your walls.
23. You must provide wood backing inside the walls to mount the various units correctly (see the attached installation print #2).
24. Be sure the supplied screws will be long enough to reach the interior wood blocking or that the screws supplied with the alligator clips are going to fit in your tile or stone walls (see diagram of suggested framing).
25. The system comes with both metal and teflon ferrules. The 2 supplied 1/2" metal ferrules are for the 1/2" copper inlets only. The teflon ferrules are for the risers on the exposed pipes only.
26. All systems have been water tested at the factory to 90 lbs of static and dynamic water pressure. Thus you may find residual water inside the thermostatic valve from this testing.

27. The exposed thermostatic valve has been factory calibrated to deliver a maximum Fahrenheit temperature of 110° to confirm proper operation. In the absence of a thermometer, the maximum water temperature should feel slightly uncomfortable to the hand.  
**NOTE:** It is important that the valve be properly calibrated to preserve its anti-scald feature. For recalibration procedures, ( See Page 8).
28. Prior to installing the thermostatic body, **flush all water lines** to free up debris. The lines should be flushed long enough to remove any sediment that may come from any new installations including a water heater. It is recommended you flush lines for at least 15 minutes before connecting the new fitting, let water run from the HOT and COLD copper connecting pipe in the shower wall.
29. **Failure to flush thoroughly may damage internal parts!** An in-line water filter is recommended to remove harmful sediments.
30. Plumber's putty is not recommended. Use of caustic substances or acidic curing products for installation purposes may harm the finish or cause the product to not function properly. Please read the cautions printed on any product purchased for use during installation. It is recommended you use teflon tape approved for water application.
31. Inlet check valves are provided with the system. If factory provided check valves are removed, a qualified plumbing contractor **MUST** install check valves up stream of the valve.
32. Water pressure comes from your local water supplier and can be measured at the source. Pressure and water velocity are not functions of the valve.
33. Do not attempt installation of product if you do not understand these instructions. **Qualified plumbers should be used for all installation procedures.**
34. Call the factory if you have any questions.

### Water Supply

Exposed Thermostatic valves can be supplied from any hot water production system, even by instantaneous domestic production, as far as the generator is capable of supplying very small quantities of hot water (about 0.8 gal/min).

- Maximum working pressure	145 PSI
- Minimum working pressure	14 PSI
- Recommended working pressure	29 to 58 PSI
- Maximum test pressure	224 PSI
- Maximum hot water temperature	185°F

**Shower Heads:**

All showerheads and hand showers comply with the approved water flow rate as required by US plumbing codes. We have installed flow restrictors in the heads.

These flow restrictors can clog from lime scale buildup, silt, sand, or debris in the water line caused from or during the construction process. If you wish to clean or service the restrictor, simply use a Phillips screwdriver and back out the plastic part - clean and reinstall.

Always keep your showerheads level and perpendicular to your floor. If any head is tilted you may not receive a satisfactory shower.

The showerheads are intentionally designed as Rain Heads. The water exits the 8" and 12" size heads like wonderful soft rain. Increased velocity does not come from the shower valve but from several other factors.

The velocity of the water is dependant on your existing street water pressure, the size of the pipes, the water meter and the design of your pipe system.

**Note:** This fitting has been factory assembled, tested and is ready for installation. See the tag attached to the valve to verify factory readiness.

## Recommended Instructions:

***Read all instructions completely before proceeding!***

The Exposed Thermostatic Valve is a controlled shower mixing valve. Temperature is thermostatically controlled by a wax cartridge thermostat that maintains a constant temperature while automatically adjusting and compensating for changes in HOT and COLD inlet pressures. Should COLD supply fail, the valve will immediately shut down to avoid any risk of scalding. Keep in mind that the distance the shower head or other exit is from the valve will determine how fast you feel the instantaneous correction in temperature. The water flow is controlled by a simple quarter turn ceramic lever. The Exposed Thermostatic Valve is suitable, without modification, for all types of installations. This includes pumped gravity systems, main pressure water systems and combination boilers.

### MEETS AND EXCEEDS I.A.P.M.O. ASSE 1016 STANDARDS AND UNIFORM PLUMBING CODES

#### PRODUCT CARE:

The Exposed Thermostatic Valve is incredibly easy to maintain. The temperature and flow are controlled by one piece cartridges which are easily removed for cleaning and replacement. To remove the thermostatic cartridge, see Calibration Instructions to demonstrate how to properly remove the handle. To ensure full water flow, periodically clean the cartridge screens of any debris using a small brush. Rinse thoroughly before returning to the fixture. Push cartridge into place and re-assemble handle pieces as shown on calibration instructions. Soaking the cartridge in a 50/50 solution of clear household vinegar and water will remove lime scale. Regular cleaning each year will extend the life of the cartridge. **Never use a screwdriver on a thermostatic cartridge and NEVER take a thermostatic cartridge apart as you will damage the precise instrument.** Call your dealer or the factory for answers to your questions.

#### INSTALLATION:

The Exposed Thermostatic Valve must be installed with the outlet pointing upwards, so that the HOT water enters on the left, and the COLD water on the right, as shown in **Figure A**. **THE VALVE WILL NOT FUNCTION IF REVERSED!** The inlet elbows are fitted with compression nuts. Be sure to **flush thoroughly all new plumbing for up to 15 minutes** before connecting the valve to clear out all debris in your water lines. The valve should be screwed to the wall with the stainless steel screws provided.

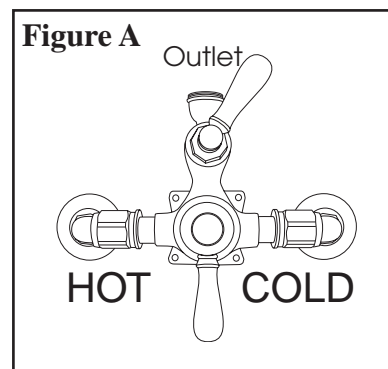

**INSTALLATION:**

Next, cut the 1/2" copper pipes so that they extend approximately 7/8" from the finished wall. **(See Figure C below)** Slip the wall flange over the pipe. Next, slide on the compression nut so that the bottom fits into the wall flange. Slide the ferrule down the pipe. It will pinch into the copper securing the elbow when you tighten the nut onto the elbow. After elbows on both sides are in place, slip the large nuts over the elbow on each side of the fitting. Next, secure the nuts to the elbows by tightening the set screws with the allen key.

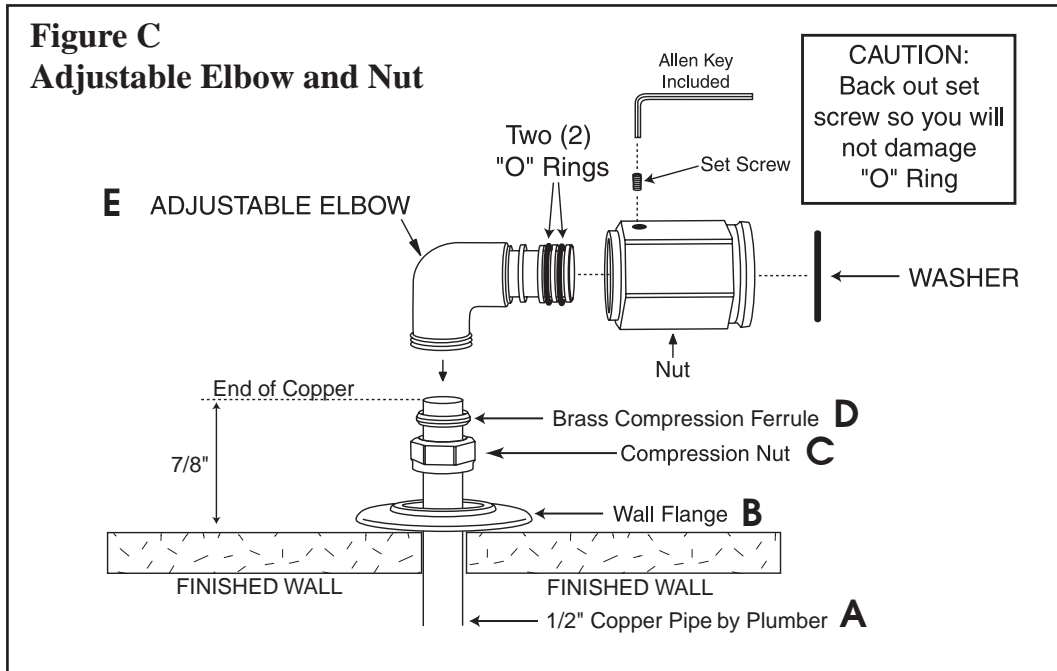

**Please Note:** The entire valve body must be installed over the copper pipes - **at one time** - you may loosen the set screw on the Large Hex Nut to allow flexibility in the installation, but do not separate the components. **See Figure D below.**

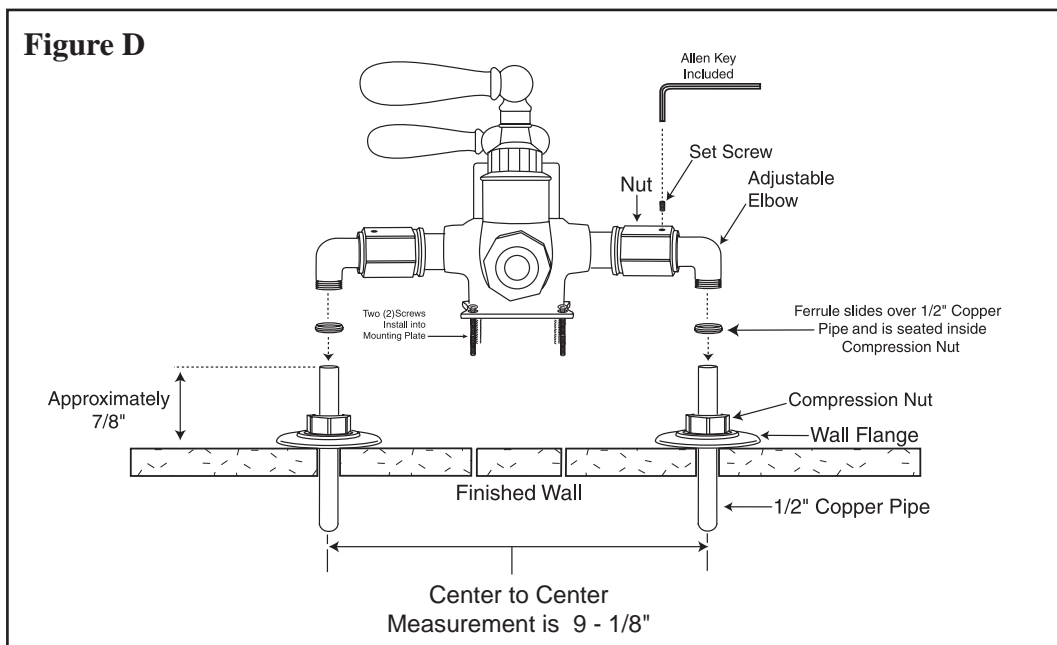

**CALIBRATION INSTRUCTIONS:**

**FOR TEMPERATURE SETTING AND ADJUSTMENTS**

Calibration is the simple process by which you control the temperature range of mixed water. The Exposed Thermostatic Valve has been tested to perform correctly at the factory, and the maximum temperature of 110°F has been set. If you desire a hotter or colder temperature range, you may recalibrate the valve after installation, when both HOT and COLD lines are 100% operational, and all installation debris has been flushed from the water lines.

**TO CALIBRATE TEMPERATURE SETTING:**

Begin by using a small screwdriver to loosen the screw located at the base of the large handle lever. Grasp firmly the center of the large handle lever and pull carefully upwards. To increase factory set temperature, rotate slowly cartridge stem (Brass Spline) counterclockwise. To reduce the temperature from factory setting, rotate cartridge stem clockwise. **See Figure D** for a full labeled diagram to assist in calibration. **Under no circumstances is the thermostatic cartridge to be dismantled. Doing so will VOID THE WARRANTY and possibly make the cartridge inoperable. Use your hand to test temperature of running water before you bathe.**

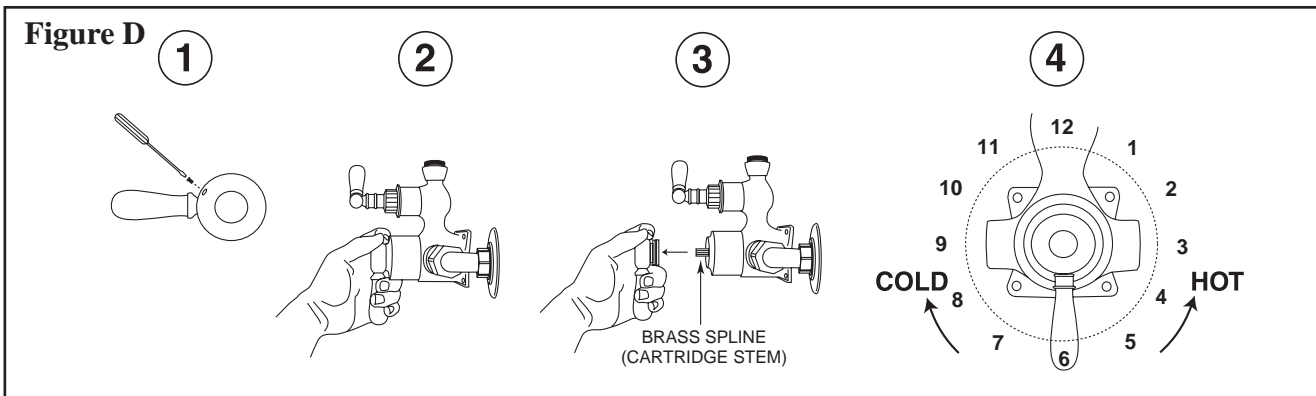

**CALIBRATION PROCEDURE**

1. To increase temperature (HOT) Turn counterclockwise.
2. To decrease temperature (COLD) turn clockwise.  
After installation, the thermostatic valve may need the Maximum Temperature Reset.
3. Undo the screw in the temperature control knob and pull it off its spline.  
**(See Figure D1 thru D3)**
4. With the shower running, turn the brass splined thermostatic cartridge with your fingers and rotate counterclockwise until a maximum HOT temperature required is reached. This should be 102°F to 108°F, or slightly uncomfortable to the hand.  
**DO NOT USE PLIERS ON THE BRASS SPLINES!**
5. Now, without turning the spindle, push the knob back onto the spindle with the handle pointing to an approximate 3 O'clock position. In this position it will be close to its stops, and when fully on will not move any further in a counterclockwise direction. Retighten the set screw, and the shower should now be set so that the user can adjust the temperature from cold to a secure and comfortable hot temperature. It is important that this calibration is carried out properly to preserve the anti-scald feature of this shower valve.

**EXPOSED 1/2" THERMOSTATIC VALVE**  
EXPLODED VIEW

**PRINT 1**

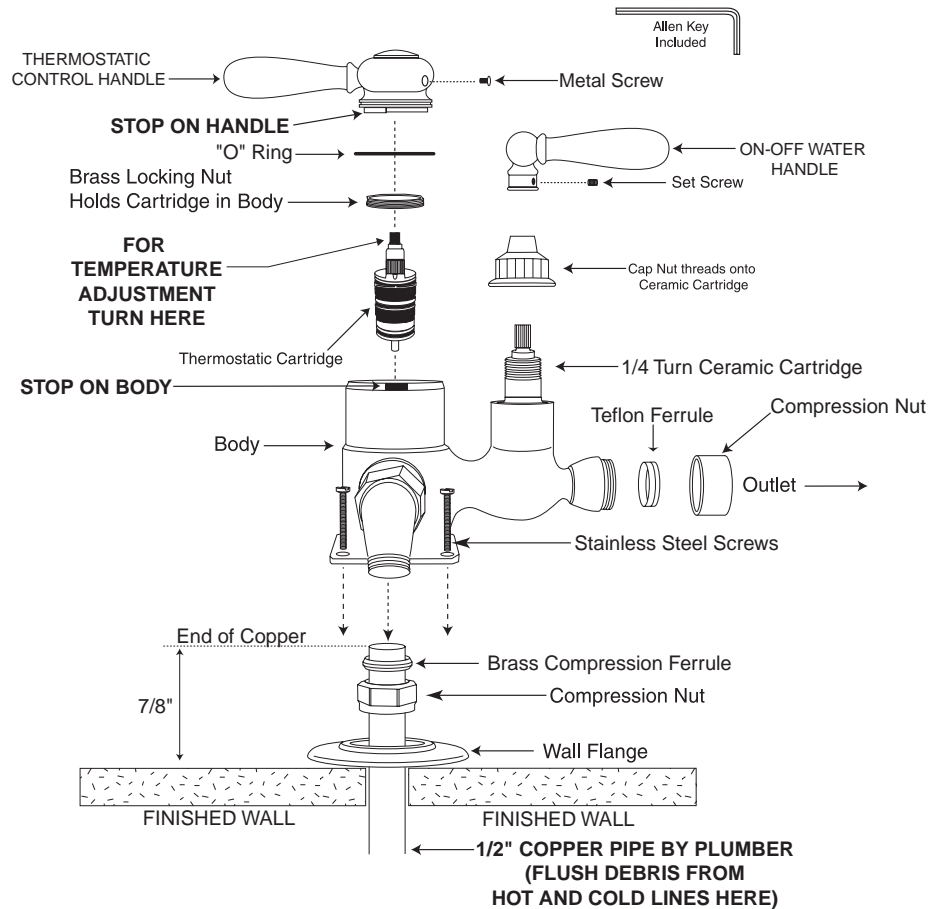

**TROUBLE SHOOTING:**

The Exposed Thermostatic valve is remarkably dependable and reliable, providing you with a lifetime of service and beauty. The following three problems, and the simple solutions to each, have accounted for nearly all difficulties with this valve.

1.) After Installation the shower only runs HOT or COLD water, and will not mix.

**SOLUTION:** You have the HOT and COLD plumbed the wrong way around. The correct plumbing is HOT on the LEFT, and COLD on the RIGHT.

2.) The shower will not run hot enough when first installed.

**SOLUTION:** First verify that the water heater is set at 135°F or more. If such is the case, then maximum temperature of the cartridge needs to be set at a higher set point. To readjust the temperature range, follow **CALIBRATION INSTRUCTIONS**.

3.) Cold water tracking through the valve into the hot system on combination boiler systems.

**SOLUTION:** This is prevented in the Exposed Thermostatic Valve by built-in check valves in the inlets. Check and clean the built-in valves.

Installation begins by selecting the centerline of 2"x 4" backings studs at the factory suggested location of 42" to 48" as shown in **(Print 2)**. The mounting plate is secured through the use of four metal screws. **Note:** The wall surface must be level on all sides of the centerline, otherwise the thermostatic system will not look level and straight when installed.

## RECOMMENDED TYPICAL WALL FRAMING CONCEPT

**PRINT 2**

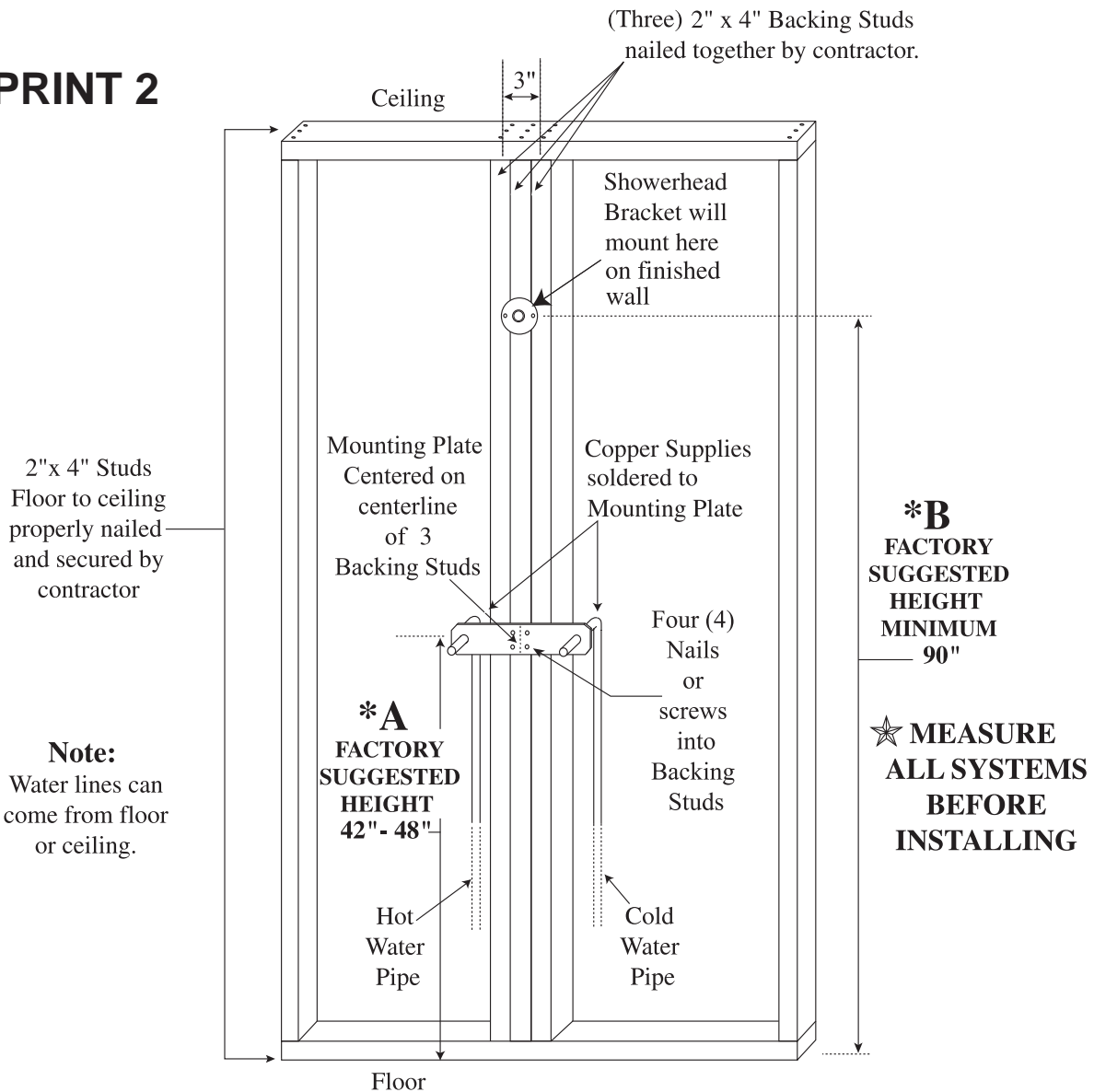

**\* Note: These are factory suggestions only - The 90" Height at \*B will allow a 6'5" tall person to walk underneath without bending.**

# Typical Finished Installation of Exposed Thermostatic Wall Units

## PRINT 3

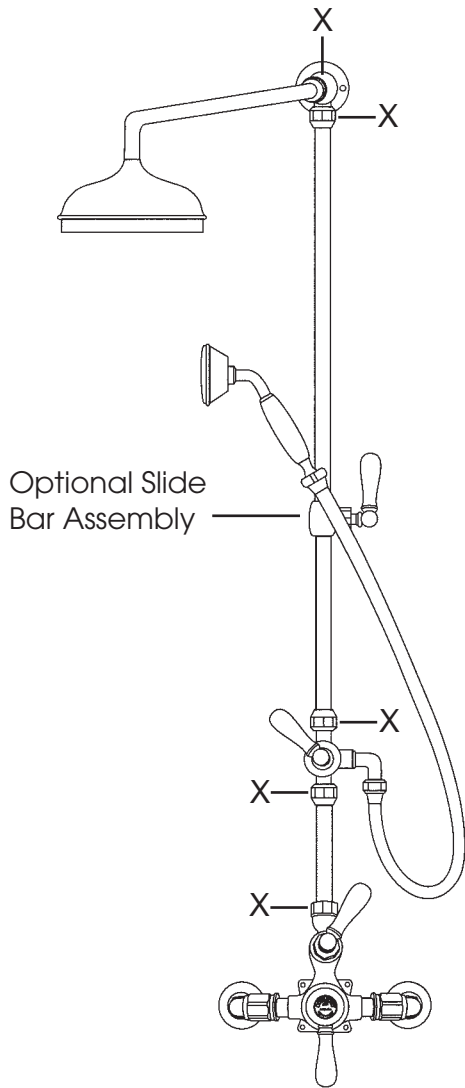

1/2" THERMOSTATIC VALVE

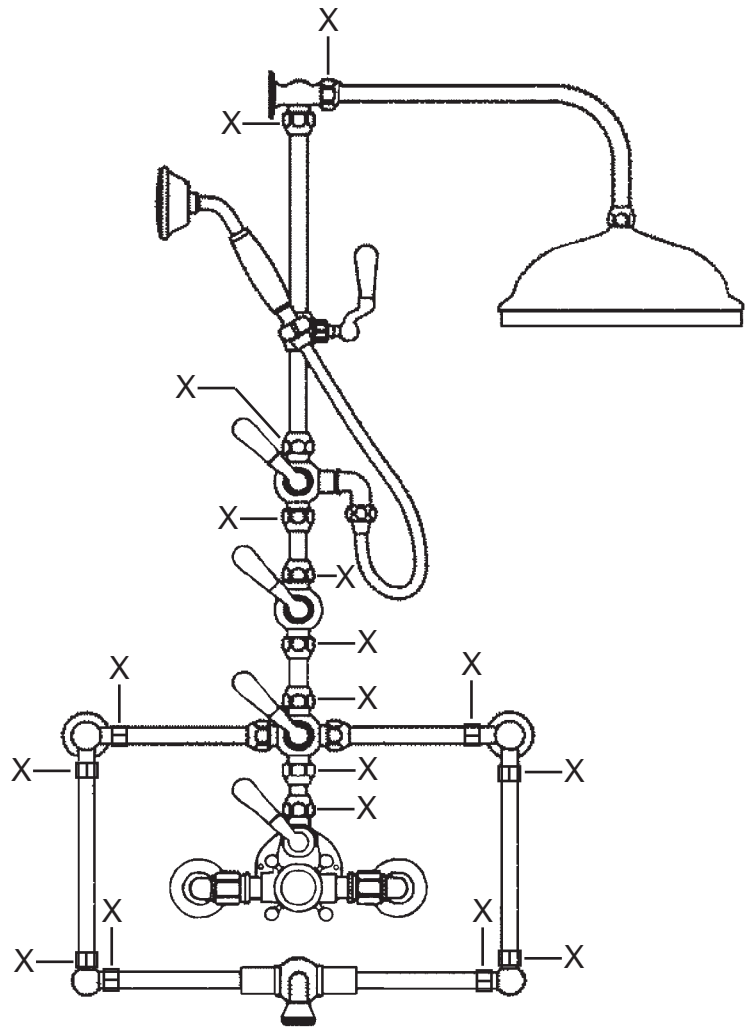

3/4" THERMOSTATIC VALVE

**Note:**

1. All Supplied Piping may be cut shorter provided there are no threads on the end you wish to cut!
2. All "X" designated points are **Teflon Compression Fittings** and the pipe can be cut by the installer to fit particular bath requirements.

**SUGGESTED INSTALLATION OF MOUNTING FOR  
1/2" EXPOSED THERMOSTATIC SYSTEM.**

THIS PLATE IS INSTALLED ON THE WOOD BACKING  
DESIGNATED ON **PRINT 2**.

**PRINT 5**

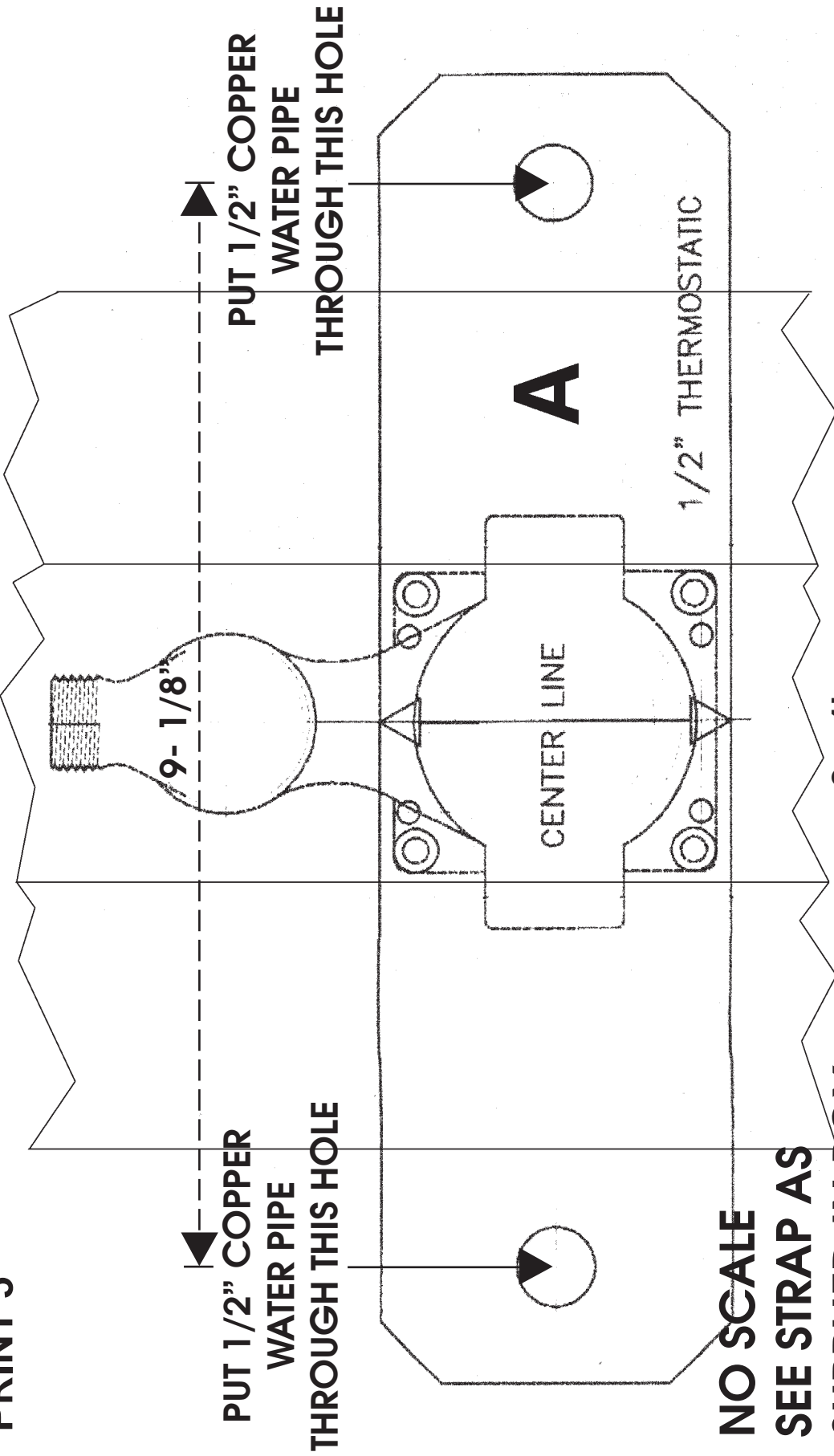

**2 x 4's**

**NO SCALE  
SEE STRAP AS  
SUPPLIED IN BOX**

#### VALVE CARE

Your 1/4 turn ceramic valve will provide you a lifetime of service when cared for properly. The most common valve problem is a result of debris in the water line, such as sand, silt, solder, metal shavings, lime deposits or other foreign particles. Debris can become lodged between the ceramic discs and result in improper functioning of the open and close action of the valve. Particles can even cause cracks in the ceramic discs and render the cartridge useless. For further information, please contact Bluewater Manufacturing Corporation @ 877-890-8006 or fax your request to 877-373-0649

#### BLUE WATER MANUFACTURING CORPORATION LIMITED PRODUCT WARRANTY

**Product/Finish Warranty:** Bluewater Manufacturing Corporation warrants that products are free from manufacturing defects in materials and workmanship for five (5) years from date of invoice. In addition, our Finish Warranty provides limited LIFETIME coverage for Chrome & PVD finishes, five (5) years for powder coated finishes & Polished Gold. Living finishes are warranted for workmanship only. If any material proves to be defective after inspection by our company, it will be repaired or replaced at our discretion at no charge. However, no claims for labor, shipping costs, or consequential damages will be accepted.

**What we will do:** We will restore any product whose finish proves to be defective back to its original finish at no charge during the appropriate warranty period stated above. Proof of purchase must be provided. After the warranty period, **Bluewater Manufacturing Corporation** will refinish any of its faucets at the prevailing appropriate charge.

**What you must do:** The faucets must be properly installed according to our instructions and specifications and are for residential use only. The faucets cannot be altered in any way. You must maintain and clean the faucets in accordance with the instructions provided with the product. You must use the faucet(s) for residential use only.

**How to obtain service:** Send your name, address, and telephone number along with a statement describing the nature of the problem and your paid sales slip or other proof of purchase to:

**BLUE WATER MANUFACTURING CORPORATION**  
3231-C Business Park Drive #31  
Vista, CA 92081

We will then contact you and take appropriate action. Do not send us any part(s) of your faucet(s) or its various connecting hoses unless we have contacted you and have sent you an approved RGA form. All transportation charges for returned goods must be paid by the customer.

**What is not covered:** This warranty does not cover the crystal/glass, or porcelain products of any faucet or the drain assembly or aerator on other than the Chrome or PVD finishes. This warranty also does not cover damage caused by accident, alterations, misuse, abuse, normal wear and tear, lime deposits, direct exposure to salty air or corrosive materials, or the color change that takes place with the passage of time, or use in any manner contrary to **Bluewater Manufacturing Corporation's** printed instructions. Cartridge warranties vary. Please call factory for details. In the case of in-the-wall installations, **Bluewater Manufacturing Corporation** will assume no liability if there is no access. **In no event will we be liable for labor of any kind, incidental or consequential damages.** This warranty is extended in lieu of all other expressed or implied warranties, whether oral or written. **Many installation compounds are harmful to brass and metal finishes. The use of any lead-based or acidic curing adhesive, silicone, mastic, or plumber's putty on or near our finished products will void the finish warranty. Use only sealants which are neutral curing and are not reactive with metal and brass finishes.** **Bluewater Manufacturing Corporation** reserves the right to change, modify or alter its products as deemed necessary. This warranty supersedes any other American Faucet & Coatings Corporation warranties, whether oral or written.

*Unless otherwise contrary to state law governing the purchase, Bluewater Manufacturing Corporation's liability will not exceed the wholesale price for the Bluewater Manufacturing Corporation product considered defective. This warranty gives you specific legal rights, and you may also have other rights which vary from state to state. Some states do not allow exclusion of incidental or consequential damages, so the above limitation may not apply to you.*

#### LIFETIME WARRANTY ON 1/4 TURN CERAMIC DISC CARTRIDGE

Should the ceramic disc cartridge in your faucet ever fail, **Bluewater Manufacturing Corporation** will replace the failed part free of charge to the original purchaser of the product. Your cost will be a \$7.95 handling and mailing charge. Labor not included. When ordering replacements, denote for widespread or centerset lavatory, Roman Tub, or other. Include age of faucet. (This does not include thermostatic, pressure balance, or diverter cartridges.)

#### NOTICE

**Bluewater Manufacturing Corporation** products are IAPMO listed and are tested to ASME A112.18.1M and ASSE 1016, and comply with Section 9 of NSF 61 for basin faucet, bar faucets, and kitchen faucets as required.