

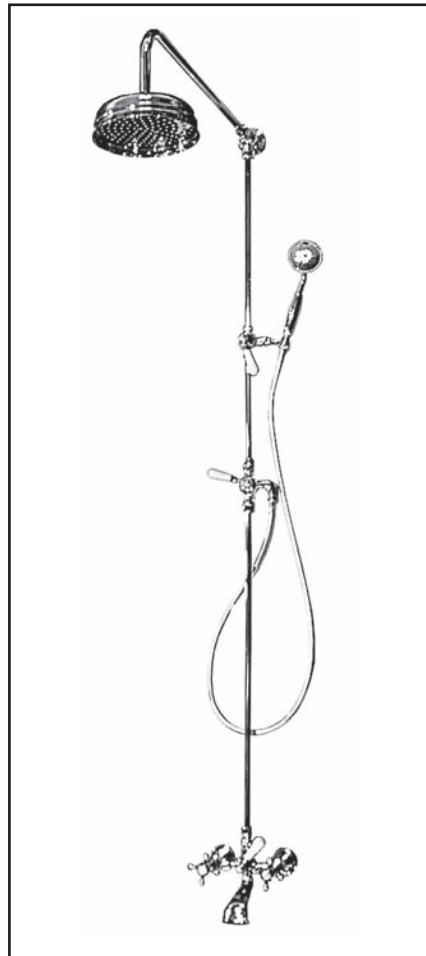

**REGIONS FOUNDRY
BRASSWORKS LTD.**

Installation Instructions for 18-440-00 and 18-430-00



- In order to meet ASSE code 1016, a remote thermostatic valve with instructions has been included with this unit. When installing, access for later maintenance and adjustment must be provided.
- Provide a back plate and attach to studs for proper stability of showerhead; shower head must be level to perform properly.
- Connect hot and cold water supplies.



**REGIONS FOUNDRY
BRASSWORKS LTD.**

**Regions Exposed Two Valve Tub/Shower Systems
Wall Mounted Version**

These exterior mounted valves are simple to install providing the following preparation is followed:

1. Turn off water.
2. Hot and cold water supply lines must be fixed at 6" center to center for wall deck and floor systems to fit.
3. The Hot and cold supply lines inside the walls should be fitted with 3/4" female adapters.
4. The installer must provide the proper length 3/4" male nipples to connect the supply lines to the exposed valve. These nipples must extend past the finished wall by 5/8". Be sure the nipples are properly sealed with teflon tape or equal prior to installing exposed valve.
5. Prior to installing the valve, flush the hot and cold water supply lines to remove all sediment, etc.
6. Next, verify that the exposed valves have 2 hard washers to seal the nipples to the 3/4" connecting female nut on the valve (See Diagram A).
7. Install the hard washers in the female connecting nut (1) each side. Wrap teflon tape on the 5/8" exposed nipple and tighten together. Use only a crescent wrench with smooth sides so no damage will occur on the nut.
8. Secure any other exposed plates to the finished wall (depending on model) and turn on the water.

**Connection of Concealed Thermostatic valve for code approved
scaled guard protection on exposed 2 valve tub and shower systems.**

Please Note: Current uniform plumbing code requires the installation of either a remote pressure balance valve or remote thermostatic valve to control the maximum hot water prior to the installation of the exposed 2 valve. The instructions for the Watts Valve are included and should be performed by a qualified installer, prior to installing this exposed tub/shower system.

Typical Exposed 2 Valve Tub/Shower System

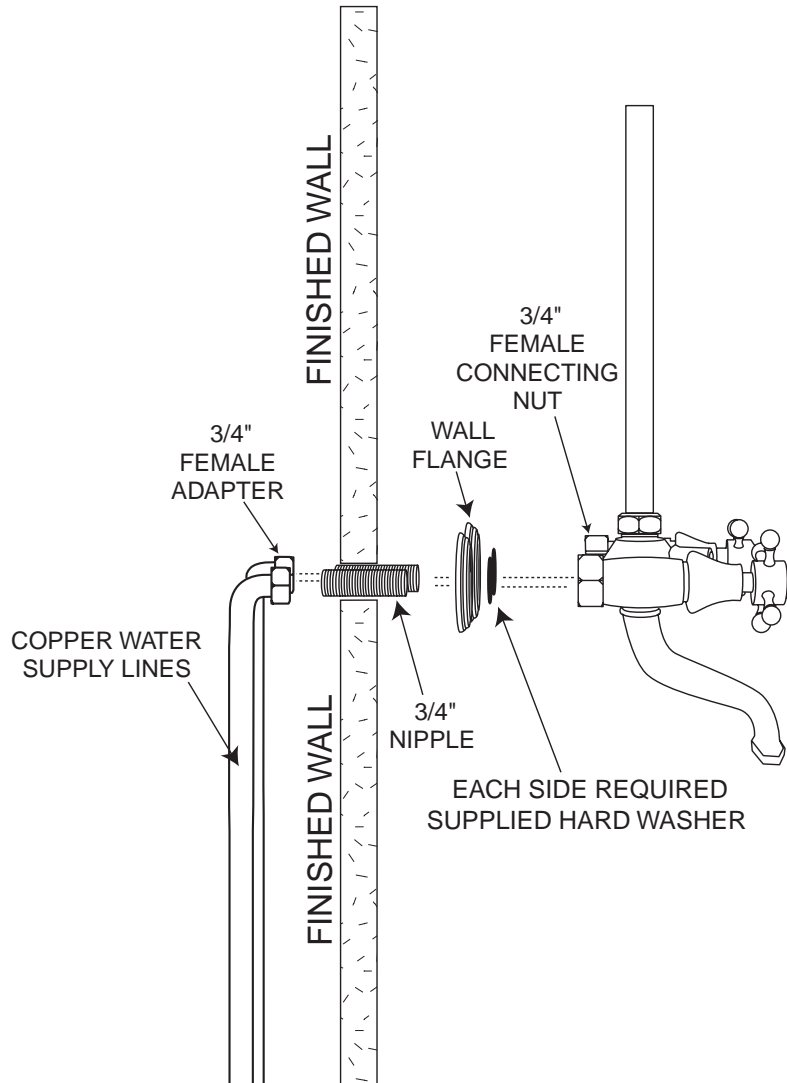

Diagram A

Installation Instructions

Watts Model MMV

Thermostatic Mixing Valve

IS-MMV 1/2"

Installation

Valve should be installed by a licensed contractor in accordance with local codes and ordinances. Further, this valve should be installed in a location where it is accessible for cleaning, service, or adjustment.

A. Piping

1. Close both the hot and cold water supply shutoff valves upstream of the intended installation.
2. Bleed the remaining water from the system.
3. Connect the water supply to the MMV valve as shown in Fig. 1. Supply piping must be flushed clean before making connections to the valve.
4. Install Watts Series CS-U combination shutoff/check valve/strainer or separate check valve, strainers and shutoff valves upstream of the MMV to facilitate servicing and temperature adjustment of the valve.

Note: All tempering valves used at the source of supply should be trapped. Trapping the valve helps reduce mineral deposits and premature component wear.

5. Start Up - Open cold water supply then hot water supply. Inspect for leaks.

ASSE 1016 Listed*

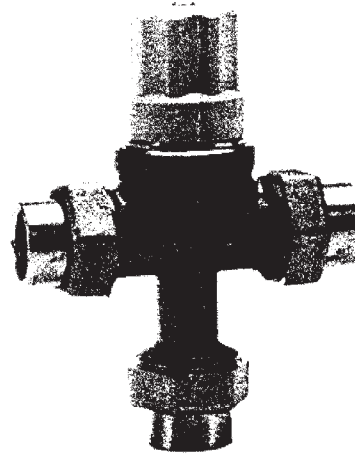

1/2" MMV

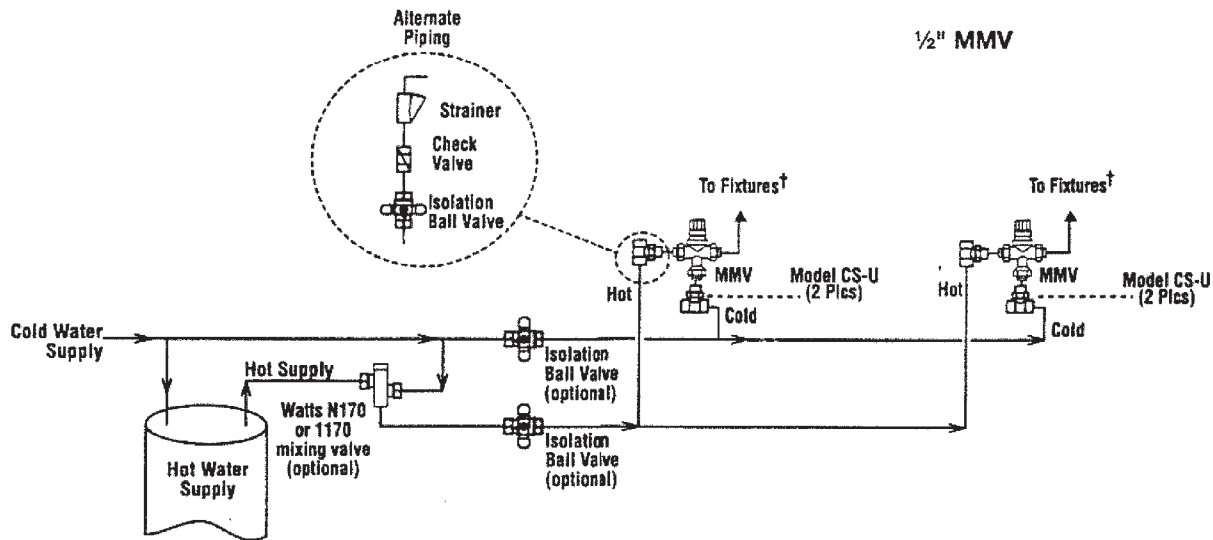

Fig. 1 Typical System Piping.
†See insets A & B on reverse side for details.

*ASSE 1016 Listing is for individual showers, baths, or a combination of both.

IMPORTANT: This valve must be maintained on a regular basis. Please see reverse side for instructions.

CAUTION: Do not use this valve on systems using a recirculation device. Systems that use recirculation to maintain selected water temperature in supply piping must incorporate master mixing valves such as the Watts N170 or 1170 series.

NOTE: When not equipped with an integral shutoff or when there is a shutoff valve installed after the control valve, there shall be stop and check valves on the inlet(s).

WARNING!

Water Temperatures in Excess of 110°F (43°C) Are Dangerous and May Cause Scalding, Severe Injury or Death!

This valve is *not* factory preset. To deliver the desired mixed water temperature at the outlet the installer must adjust and verify the temperature at the outlet.

Important!

This valve can be adjusted to deliver water at temperatures exceeding 110°F (43°C). Consequently, after installing the Watts MMV Thermostatic Mixing Valve, you should always check the outlet water temperature and adjust the valve to ensure delivery of water at a safe temperature not exceeding 110°F (43°C). Further, check valves and strainers must be installed in the hot and cold water supply lines to this valve. Mechanical valves are not fail-safe. Due to the effects of various water conditions, periodic verification of water temperature is required.

Installation continued

B. Temperature Adjustment

1. Open hot and cold water supply valves.
2. Open mixed water outlet.
3. With the fixture in the full open position, calibrate the mixed water outlet temperature by placing a thermometer in the mixed water stream. (**Note:** Loosen locking cap screw with hex wrench provided. Cap must be partially lifted to adjust temperature.) Adjust the setting of the MMV valve to obtain the desired temperature (counterclockwise, to increase temperature — clockwise to decrease temperature).

C. Periodic Inspection/Maintenance

This valve requires periodic inspection and verification of the outlet temperature by a licensed contractor. Corrosive water conditions, hot feed water temperatures over 200°F (93°C), unauthorized adjustments or repair could render the valve ineffective for its intended service. Regular cleaning and checking of thermostat assembly helps to maximize valve life and mixing function. Frequency of cleaning depends on local water conditions.

NOTE: Refer to MMV Repair Kit for detailed information on replacement parts.

Typical ASSE 1016 installation*

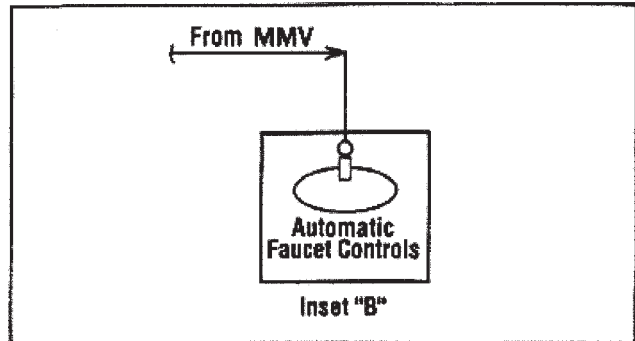
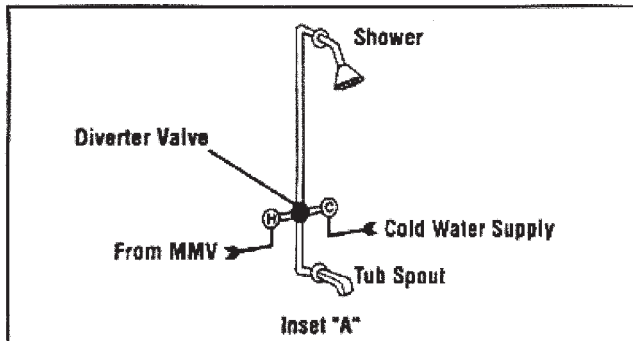

*ASSE 1016 Listing is for individual showers, baths, or a combination of both.

Watts product specifications in U.S. customary units and metric are approximate and are provided for reference only. Watts reserves the right to change or modify product design, construction, specifications, or materials without prior notice and without incurring any obligation to make such changes and modifications on Watts products previously or subsequently sold.

LIMITED WARRANTY: Watts Regulator Company warrants each product against defects in material and workmanship for a period of one year from the date of original shipment. In the event of such defects within the warranty period, the Company will, at its option, replace or recondition the product without charge. This shall constitute the exclusive remedy for breach of warranty, and the Company shall not be responsible for any incidental or consequential damages, including without limitation, damages or other costs resulting from labor charges, delays, vandalism, negligence, fouling caused by foreign material, damage from adverse water conditions, chemicals, or any other circumstances over which the Company has no control. This warranty shall be invalidated by any abuse, misuse, misapplication or improper installation of the product. **THE COMPANY MAKES NO OTHER WARRANTIES EXPRESS OR IMPLIED EXCEPT AS PROVIDED IN THIS LIMITED WARRANTY.**

CALIFORNIA PROPOSITION 65 WARNING

WARNING: This product contains chemicals known to the State of California to cause cancer and birth defects or other reproductive harm.
(Installer: California law requires that this warning be given to the consumer.)



USA: 815 Chestnut St., No. Andover, MA 01845-6098; www.wattsreg.com
Canada: 5435 Norm Service Rd., Burlington, ONT. L7L 5H7; www.wattsca.com



IS-MMV-1/2"0029

EDP# 1915217

© Watts Regulator Co., 1997

Printed in U.S.A.

Bluewater Manufacturing Corporation Phone # 877-890-8006 Fax # 877-373-0649

VALVE CARE

Your 1/4 turn ceramic valve will provide you a lifetime of service when cared for properly. The most common valve problem is a result of debris in the water line, such as sand, silt, solder, metal shavings, lime deposits or other foreign particles. Debris can become lodged between the ceramic discs and result in improper functioning of the open and close action of the valve. Particles can even cause cracks in the ceramic discs and render the cartridge useless. For further information, please contact Bluewater Manufacturing Corporation @ 877-890-8006 or fax your request to 877-373-0649

BLUE WATER MANUFACTURING CORPORATION LIMITED PRODUCT WARRANTY

Product/Finish Warranty: Bluewater Manufacturing Corporation warrants that products are free from manufacturing defects in materials and workmanship for five (5) years from date of invoice. In addition, our Finish Warranty provides limited LIFETIME coverage for Chrome & PVD finishes, five (5) years for powder coated finishes & Polished Gold. Living finishes are warranted for workmanship only. If any material proves to be defective after inspection by our company, it will be repaired or replaced at our discretion at no charge. However, no claims for labor, shipping costs, or consequential damages will be accepted.

What we will do: We will restore any product whose finish proves to be defective back to its original finish at no charge during the appropriate warranty period stated above. Proof of purchase must be provided. After the warranty period, **Bluewater Manufacturing Corporation** will refinish any of its faucets at the prevailing appropriate charge.

What you must do: The faucets must be properly installed according to our instructions and specifications and are for residential use only. The faucets cannot be altered in any way. You must maintain and clean the faucets in accordance with the instructions provided with the product. You must use the faucet(s) for residential use only.

How to obtain service: Send your name, address, and telephone number along with a statement describing the nature of the problem and your paid sales slip or other proof of purchase to:

BLUE WATER MANUFACTURING CORPORATION
3231-C Business Park Drive #31
Vista, CA 92081

We will then contact you and take appropriate action. Do not send us any part(s) of your faucet(s) or its various connecting hoses unless we have contacted you and have sent you an approved RGA form. All transportation charges for returned goods must be paid by the customer.

What is not covered: This warranty does not cover the crystal/glass, or porcelain products of any faucet or the drain assembly or aerator on other than the Chrome or PVD finishes. This warranty also does not cover damage caused by accident, alterations, misuse, abuse, normal wear and tear, lime deposits, direct exposure to salty air or corrosive materials, or the color change that takes place with the passage of time, or use in any manner contrary to **Bluewater Manufacturing Corporation's** printed instructions. Cartridge warranties vary. Please call factory for details. In the case of in-the-wall installations, **Bluewater Manufacturing Corporation** will assume no liability if there is no access. **In no event will we be liable for labor of any kind, incidental or consequential damages.** This warranty is extended in lieu of all other expressed or implied warranties, whether oral or written. **Many installation compounds are harmful to brass and metal finishes. The use of any lead-based or acidic curing adhesive, silicone, mastic, or plumber's putty on or near our finished products will void the finish warranty. Use only sealants which are neutral curing and are not reactive with metal and brass finishes.** **Bluewater Manufacturing Corporation** reserves the right to change, modify or alter its products as deemed necessary. This warranty supersedes any other American Faucet & Coatings Corporation warranties, whether oral or written.

Unless otherwise contrary to state law governing the purchase, Bluewater Manufacturing Corporation's liability will not exceed the wholesale price for the Bluewater Manufacturing Corporation product considered defective. This warranty gives you specific legal rights, and you may also have other rights which vary from state to state. Some states do not allow exclusion of incidental or consequential damages, so the above limitation may not apply to you.

LIFETIME WARRANTY ON 1/4 TURN CERAMIC DISC CARTRIDGE

Should the ceramic disc cartridge in your faucet ever fail, **Bluewater Manufacturing Corporation** will replace the failed part free of charge to the original purchaser of the product. Your cost will be a \$7.95 handling and mailing charge. Labor not included. When ordering replacements, denote for widespread or centerset lavatory, Roman Tub, or other. Include age of faucet. (This does not include thermostatic, pressure balance, or diverter cartridges.)

NOTICE

Bluewater Manufacturing Corporation products are IAPMO listed and are tested to ASME A112.18.1M and ASSE 1016, and comply with Section 9 of NSF 61 for basin faucet, bar faucets, and kitchen faucets as required.