



**REGIONS FOUNDRY
BRASSWORKS LTD.**

Single Hole Bidet Set Installation Instructions



LEAVE FOR HOME OWNER

All Regions Brassworks products satisfy all ANSI/ASME test requirements for USA.

TESTED TO ASME
A112.18.1M/ASSE 1016

FLOW RATES:
SHOWER HEADS 2.5 GPM/9.5 LPM,
AERATORS 2.2GPM/8.3 LPM

Regions Brassworks products comply with Section 9 of NSF 61 criteria concerning lead content.

Care Instructions:

The Regions Brassworks Product you have just purchased is designed to provide you with long lasting beauty and dependability. To ensure your product's longevity, please follow the following care instructions.

When installing, we recommend you lay all parts on a soft cloth or towel to avoid scratching or damaging the product. Never use abrasive cleansers, sponges, or acidic cleaning products as these may damage the finish and VOID THE WARRANTY.

Note: This fitting has been factory assembled, tested and is ready for installation.

Recommended Installation Instructions:

Read all instructions completely before proceeding!

Step 1:

Unscrew the nut from the bottom of the faucet, then remove the metal mounting bracket and the two rubber washers as shown in Figure 1.

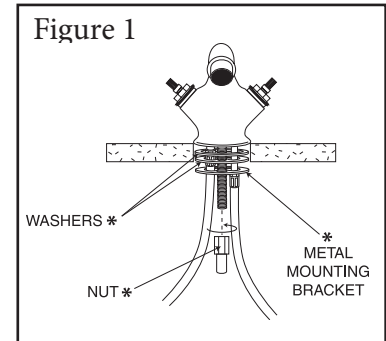

Step 2:

Place the spout shank with attached stainless hoses through the top hole in the deck or plumbing fixture. Making sure ALL washers are in place as shown, secure the fitting to the fixture by reapplying the nut and tightening it.

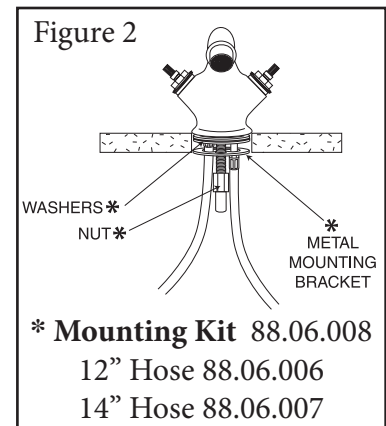

Step 3:

Connect the flexible stainless hoses to the HOT and COLD water supplies. Hand tighten only, do NOT use a wrench. These hoses are self sealing and over tightening is not required.

Step 4:

Disassemble the standard drain parts as shown in Figure 4. Remove all washers and nuts. Place the upper portion of the main drain body through the drain hole, then secure using nuts and washers.

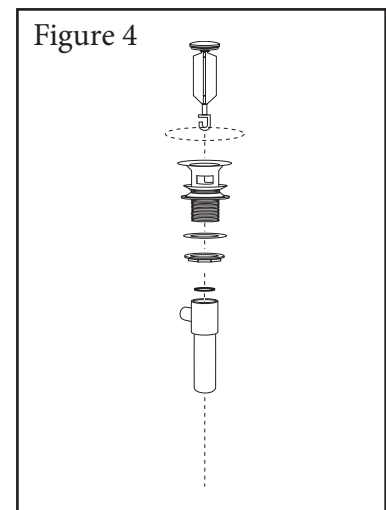

Step 5:

Attach the lower portion of the drain body to the upper portion, making sure the ball rod opening faces the rear of the sink. Carefully insert the ball rod so that it goes through the hook in the plunger. Hand tighten the ball rod nut. Insert the other end of the ball rod through the bottom of the pop-up strap as shown in Figure 5.

Step 6:

After placing pop-up rod through the top of the spout, insert the end into the pop-up strap. Adjust rise and seal of the drain plug before tightening the screw on the strap. When installation is complete, check the system for any leaks.

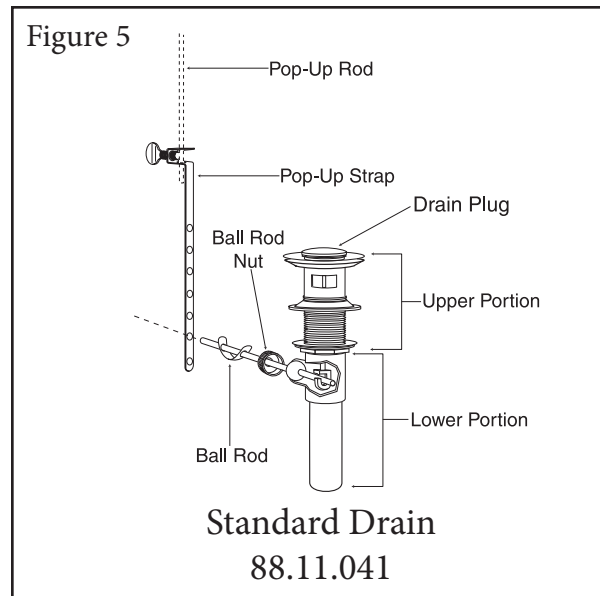

⚠ CAUTIONS ⚠

- *Take special care to protect all components during the construction and installation.*
- *Before removal of old faucet, always turn off water.*
- *Open the faucets to reduce water pressure and to insure that complete water shut off has been accomplished.*
- *Before faucet installation, carefully flush all water lines.*
- *After faucet installation, remove aerator and flush all water lines again. FAILURE TO DO SO MAY DAMAGE INTERNAL PARTS!*
- *Plumber's putty is not recommended. Use of caustic substances may harm the finish or cause the product to not function properly.*

VALVE CARE

Your 1/4 turn ceramic valve will provide you a lifetime of service when cared for properly. The most common valve problem is a result of debris in the water line, such as sand, silt, solder, metal shavings, lime deposits or other foreign particles. Debris can become lodged between the ceramic discs and result in improper functioning of the open and close action of the valve. Particles can even cause cracks in the ceramic discs and render the cartridge useless. For further information, please contact Bluewater Manufacturing Corporation @ 877-890-8006 or fax your request to 877-373-0649

**BLUE WATER MANUFACTURING CORPORATION
LIMITED PRODUCT WARRANTY**

Product/Finish Warranty: Bluewater Manufacturing Corporation warrants that products are free from manufacturing defects in materials and workmanship for five (5) years from date of invoice. In addition, our Finish Warranty provides limited LIFETIME coverage for Chrome & PVD finishes, five (5) years for powder coated finishes & Polished Gold. Living finishes are warranted for workmanship only. If any material proves to be defective after inspection by our company, it will be repaired or replaced at our discretion at no charge. However, no claims for labor, shipping costs, or consequential damages will be accepted.

What we will do: We will restore any product whose finish proves to be defective back to its original finish at no charge during the appropriate warranty period stated above. Proof of purchase must be provided. After the warranty period, **Bluewater Manufacturing Corporation** will refinish any of its faucets at the prevailing appropriate charge.

What you must do: The faucets must be properly installed according to our instructions and specifications and are for residential use only. The faucets cannot be altered in any way. You must maintain and clean the faucets in accordance with the instructions provided with the product. You must use the faucet(s) for residential use only.

How to obtain service: Send your name, address, and telephone number along with a statement describing the nature of the problem and your paid sales slip or other proof of purchase to:

**BLUE WATER MANUFACTURING CORPORATION
3231-C Business Park Drive #31
Vista, CA 92081**

We will then contact you and take appropriate action. Do not send us any part(s) of your faucet(s) or its various connecting hoses unless we have contacted you and have sent you an approved RGA form. All transportation charges for returned goods must be paid by the customer.

What is not covered: This warranty does not cover the crystal/glass, or porcelain products of any faucet or the drain assembly or aerator on other than the Chrome or PVD finishes. This warranty also does not cover damage caused by accident, alterations, misuse, abuse, normal wear and tear, lime deposits, direct exposure to salty air or corrosive materials, or the color change that takes place with the passage of time, or use in any manner contrary to **Bluewater Manufacturing Corporation's** printed instructions. Cartridge warranties vary. Please call factory for details. In the case of in-the-wall installations, **Bluewater Manufacturing Corporation** will assume no liability if there is no access. **In no event will we be liable for labor of any kind, incidental or consequential damages.** This warranty is extended in lieu of all other expressed or implied warranties, whether oral or written. **Many installation compounds are harmful to brass and metal finishes. The use of any lead-based or acidic curing adhesive, silicone, mastic, or plumber's putty on or near our finished products will void the finish warranty. Use only sealants which are neutral curing and are not reactive with metal and brass finishes. Bluewater Manufacturing Corporation** reserves the right to change, modify or alter its products as deemed necessary. This warranty supersedes any other American Faucet & Coatings Corporation warranties, whether oral or written.

*Unless otherwise contrary to state law governing the purchase, **Bluewater Manufacturing Corporation's** liability will not exceed the wholesale price for the **Bluewater Manufacturing Corporation** product considered defective. This warranty gives you specific legal rights, and you may also have other rights which vary from state to state. Some states do not allow exclusion of incidental or consequential damages, so the above limitation may not apply to you.*

LIFETIME WARRANTY ON 1/4 TURN CERAMIC DISC CARTRIDGE

Should the ceramic disc cartridge in your faucet ever fail, **Bluewater Manufacturing Corporation** will replace the failed part free of charge to the original purchaser of the product. Your cost will be a \$7.95 handling and mailing charge. Labor not included. When ordering replacements, denote for widespread or centerset lavatory, Roman Tub, or other. Include age of faucet. (This does not include thermostatic, pressure balance, or diverter cartridges.)

NOTICE

Bluewater Manufacturing Corporation products are IAPMO listed and are tested to ASME A112.18.1M and ASSE 1016, and comply with Section 9 of NSF 61 for basin faucet, bar faucets, and kitchen faucets as required.