

bluewater®

manufacturing corporation

WALL MOUNT LAV SET

INSTALLATION INSTRUCTIONS

Please read these instructions and cautions contained in this booklet before installation.



Step 1

Carefully review all preassembled parts. It will be necessary for the various parts to be reassembled exactly as shown.

Step 2

Install rough plumbing in desired location within the wall. All copper fittings including TEE supplied by others. Valve stem must be set so as the tip of the stem is at the specified distance from the finished wall (see roughing-in chart below for the trim design on this fitting).

1. Rough-in Measurement A is from tip of valve stem to finished wall.
2. For extra wall thickness, such as ceramic tile, place the in-wall valve body as necessary to maintain Measurement A.
3. Never use an exit as an inlet; Never use an inlet as an exit.
4. Follow arrow marked on body for water flow direction.
5. All connections are female NPT fittings.
9. Trim stem and threads as necessary.
6. No heat-No torch.
7. FLUSH LINES OF DEBRIS.
8. TEST UNIT BEFORE CLOSING WALL.
10. UPC REQUIRES ACCESS TO MECHANICAL JOINTS.

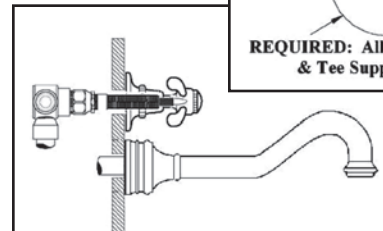
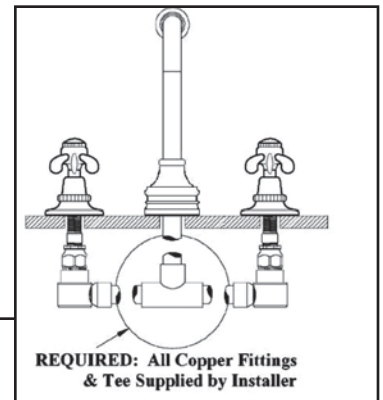
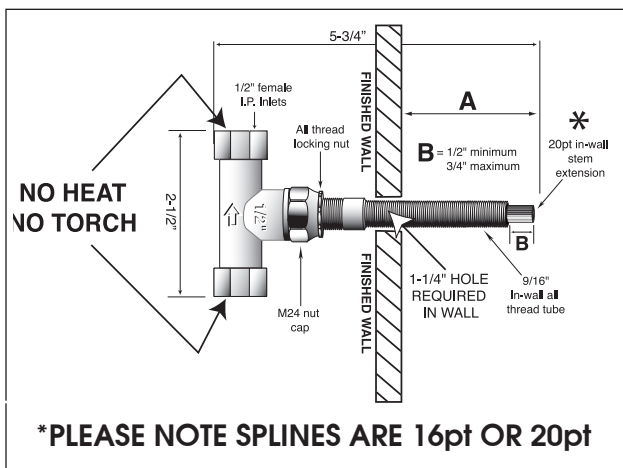

Handles with* Requires special bushing.

Part # 77.03.435B

*PLEASE NOTE SPLINES ARE 16pt OR 20pt

Use two or three digit number below as center number in product code (example 21.701.10)

Handle Group	Measurement A
Design Group I 507, 701, 702, 703	1-1/2"
Design Group II 04, 06, 07, 10, 500, 501*, 503*, 506, 509*, 512, 800, 801, 803, 809	1-3/4"
Design Group III 05, 08, 09, 16, 20, 30, 40, 50, 505, 508, 510*, 511, 513, 808, 810, 811, 813	2"
Design Group IV 515, 516, 816	2-1/4"
Design Group V 301, 302, 02, 03, 12, 13, 14, 502, 504, 804	2-1/2"
Design Group VI 303	2-3/4"
Design Group VII 601, 602, 603, 604	3-1/4"

NOTICE: These instructions do not represent step-by-step directions. They are a product supplement only to be used by a qualified/licensed plumber. We recommend all plumbing fixtures be installed by a professional.

VALVE CARE

Your 1/4 turn ceramic valve will provide you a lifetime of service when cared for properly. The most common valve problem is a result of debris in the water line, such as sand, silt, solder, metal shavings, lime deposits or other foreign particles. Debris can become lodged between the ceramic discs and result in improper functioning of the open and close action of the valve. Particles can even cause cracks in the ceramic discs and render the cartridge useless. For further information, please contact Bluewater Manufacturing Corporation @ 877-890-8006 or fax your request to 877-373-0649

**BLUE WATER MANUFACTURING CORPORATION
LIMITED PRODUCT WARRANTY**

Product/Finish Warranty: Bluewater Manufacturing Corporation warrants that products are free from manufacturing defects in materials and workmanship for five (5) years from date of invoice. In addition, our Finish Warranty provides limited LIFETIME coverage for Chrome & PVD finishes, five (5) years for powder coated finishes & Polished Gold. Living finishes are warranted for workmanship only. If any material proves to be defective after inspection by our company, it will be repaired or replaced at our discretion at no charge. However, no claims for labor, shipping costs, or consequential damages will be accepted.

What we will do: We will restore any product whose finish proves to be defective back to its original finish at no charge during the appropriate warranty period stated above. Proof of purchase must be provided. After the warranty period, **Bluewater Manufacturing Corporation** will refinish any of its faucets at the prevailing appropriate charge.

What you must do: The faucets must be properly installed according to our instructions and specifications and are for residential use only. The faucets cannot be altered in any way. You must maintain and clean the faucets in accordance with the instructions provided with the product. You must use the faucet(s) for residential use only.

How to obtain service: Send your name, address, and telephone number along with a statement describing the nature of the problem and your paid sales slip or other proof of purchase to:

**BLUE WATER MANUFACTURING CORPORATION
3231-C Business Park Drive #31
Vista, CA 92081**

We will then contact you and take appropriate action. Do not send us any part(s) of your faucet(s) or its various connecting hoses unless we have contacted you and have sent you an approved RGA form. All transportation charges for returned goods must be paid by the customer.

What is not covered: This warranty does not cover the crystal/glass, or porcelain products of any faucet or the drain assembly or aerator on other than the Chrome or PVD finishes. This warranty also does not cover damage caused by accident, alterations, misuse, abuse, normal wear and tear, lime deposits, direct exposure to salty air or corrosive materials, or the color change that takes place with the passage of time, or use in any manner contrary to **Bluewater Manufacturing Corporation's** printed instructions. Cartridge warranties vary. Please call factory for details. In the case of in-the-wall installations, **Bluewater Manufacturing Corporation** will assume no liability if there is no access. **In no event will we be liable for labor of any kind, incidental or consequential damages.** This warranty is extended in lieu of all other expressed or implied warranties, whether oral or written. **Many installation compounds are harmful to brass and metal finishes. The use of any lead-based or acidic curing adhesive, silicone, mastic, or plumber's putty on or near our finished products will void the finish warranty. Use only sealants which are neutral curing and are not reactive with metal and brass finishes.** **Bluewater Manufacturing Corporation** reserves the right to change, modify or alter its products as deemed necessary. This warranty supersedes any other American Faucet & Coatings Corporation warranties, whether oral or written.

*Unless otherwise contrary to state law governing the purchase, **Bluewater Manufacturing Corporation's** liability will not exceed the wholesale price for the **Bluewater Manufacturing Corporation** product considered defective. This warranty gives you specific legal rights, and you may also have other rights which vary from state to state. Some states do not allow exclusion of incidental or consequential damages, so the above limitation may not apply to you.*

LIFETIME WARRANTY ON 1/4 TURN CERAMIC DISC CARTRIDGE

Should the ceramic disc cartridge in your faucet ever fail, **Bluewater Manufacturing Corporation** will replace the failed part free of charge to the original purchaser of the product. Your cost will be a \$7.95 handling and mailing charge. Labor not included. When ordering replacements, denote for widespread or centerset lavatory, Roman Tub, or other. Include age of faucet. (This does not include thermostatic, pressure balance, or diverter cartridges.)

NOTICE

Bluewater Manufacturing Corporation products are IAPMO listed and are tested to ASME A112.18.1M and ASSE 1016, and comply with Section 9 of NSF 61 for basin faucet, bar faucets, and kitchen faucets as required.

Bluewater Manufacturing Corporation