

DECKMOUNT LAVATORY INSTALLATION GUIDE #001 PAGE 1 OF 3

PLEASE INSPECT PRODUCT PRIOR TO INSTALLING. Carefully review all pre-assembled parts. It will be necessary for the various parts to be re-assembled exactly as shown. **NOTICE:** These instructions do not represent step-by-step directions. They are a product supplement only to be used by a qualified/licensed plumber. We recommend all plumbing fixtures be installed by a professional.

VALVE INSTALLATION STEPS

STEP #1:
Review the factory pre-assembled lav valve and handle trim as supplied. Part #'s 1 - 2 - 3 - 4 - 5 and 6 are completely assembled at the factory and should not be dis-assembled. The handle assembly is removed from Deck Mounting Collar #7 by loosening Set Screw #4 with factory supplied Allen Key.

STEP #2:
Remove Deck Mount Collar #7 by unscrewing from Lav Body #10. **NOTE: Part #9 - the Broached Adapter is loose, be careful not to misplace during dis-assembly procedure.**

Next, set aside Collar #7 and Spacer #8. Then insert Lav Valve #10 through bottom of counter/sink and re-assemble #8 Spacer and Collar #7 onto Lav Valve #10.

NOTE: #8 Spacer is optional - Spacer is required for thin tops on sinks only.

Finally rotate Collar #7 securely onto Valve #10 - Make sure Plastic Bottom Nut is secured using proper wrench. We recommend that the valve outlets are facing the spout as shown in Drawing A.

STEP #3:
Drop factory assembled handle 1 through 6 onto Collar #7. Align the assembly as required and tighten with set screw #4.

STEP #4:
Using the included hoses connect the lav valves to the spout tee assembly. Plumb supply lines to valves taking consideration for the above valve care precautions.

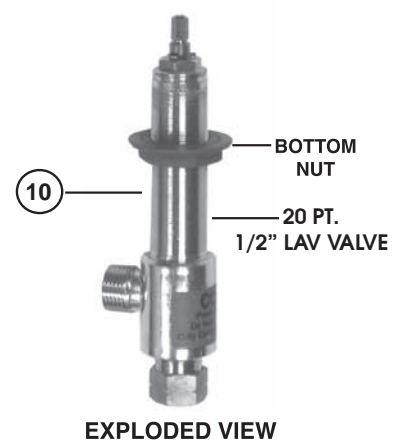
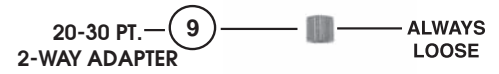
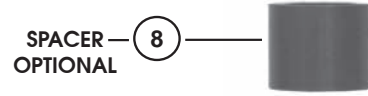
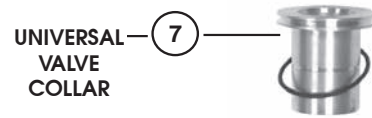
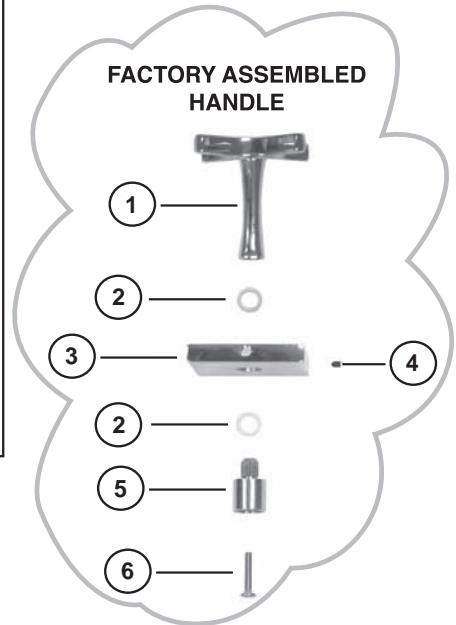
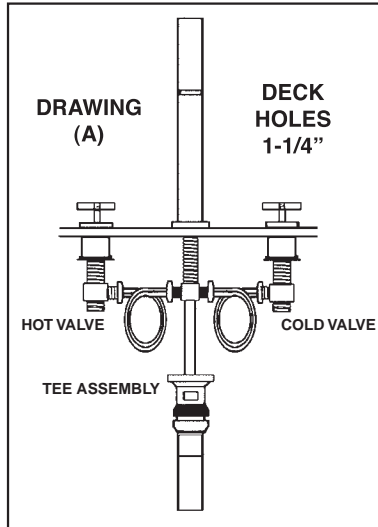

Item	Qty	Description	Part #
1	--	TYPICAL HANDLE (pre-assembled at factory)	SPECIFY HANDLE
2	1	PLASTIC WASHER	88.01.225
3	1	TYPICAL ESCUTCHEON	SPECIFY ROUND OR SQUARE
4	1	SET SCREW 8 - 32 x 1/8 CONE	19.01.083
5	1	2-WAY ADAPTER 30 - 20 PT.	88.30.313
6	1	M4-20 SCREW	88.30.314
7	1	UNIVERSAL VALVE COLLAR	88.30.315
8	1	SPACER	88.30.316
9	1	2-WAY ADAPTER 20 - 30 PT.	88.30.317
10	1	VALVE BODY 20 PT.	SPECIFY HOT OR COLD

**TYPICAL DECK MOUNT
LAV SPOUT
INSTALLATION INSTRUCTIONS #001A PAGE 2 OF 3**

PLEASE INSPECT PRODUCT PRIOR TO INSTALLING. Carefully review all pre-assembled parts. It will be necessary for the various parts to be re-assembled exactly as shown. **NOTICE:** These instructions do not represent step-by-step directions. They are a product supplement only to be used by a qualified/licensed plumber. We recommend all plumbing fixtures be installed by a professional.

NOTE: SEE DECKMOUNT LAV VALVE AND TRIM #001

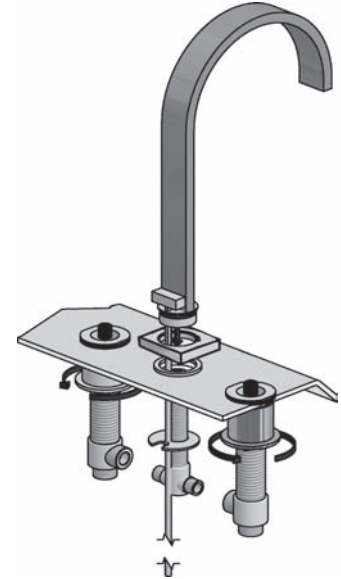

STEP #1: Remove 3 way tee, single nipple mounting nut and metal lock washer from the spout shank. Placing the spout base with escutcheon thru the deck hole.

STEP #2: Tighten the escutcheon to the spout base with the included set screw - if needed.

STEP #3: Insert the pop-up rod through the escutcheon base (part #4) and down through the deck hole of spout assembly (part #1).

STEP #4: From below the deck install the metal lock washer (part #5) with notch to the rear as a guide for the pop-up rod .

STEP #5: Screw on the holding nut (part #6) to secure spout to deck - make secure so the spout will not swivel.

STEP #6: Screw on the 3-way tee assembly (part #8) with flow restrictor (part #7).

STEP #7: Using supplied stainless steel connecting hoses, connect to installed lav valve.

STEP #8: Connect supplied pop-up drain to complete installation.

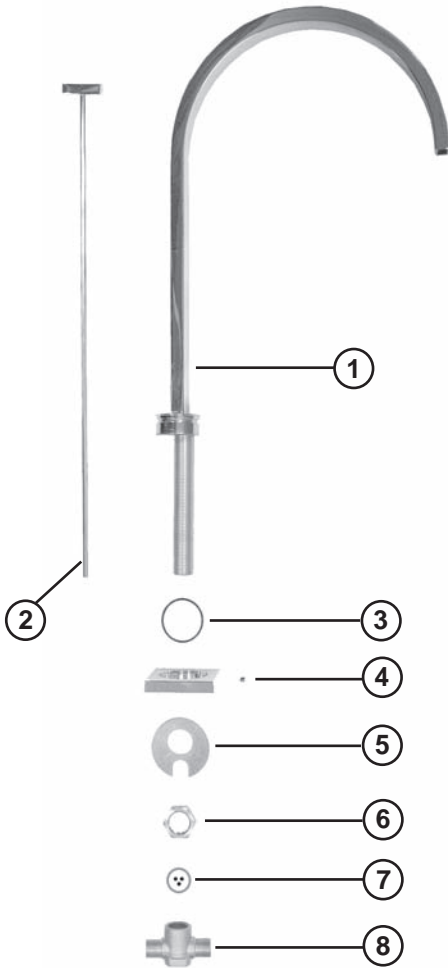

Item	Qty	Description	Part #
1	1	TYPICAL SPOUT (preassembled at factory)	88.07.032
2	1	POP-UP ROD & KNOB	88.11.285
3	1	SPOUT BASE O-RING	88.07.210
4	1	SPOUT BASE ESCUTCHEON W/ SET SCREW	SPECIFY ROUND OR SQUARE
5	1	METAL LOCK WASHER	88.07.045
6	1	SINGLE NIPPLE HOLDING NUT	88.07.044
7	1	FLOW RESTRICTOR	88.07.043
8	1	3-WAY TEE ASSEMBLY	88.07.041

**TYPICAL RIBBON SERIES LAV SET
VISUAL ASSEMBLY DETAILS
SEE INSTALLATION INSTRUCTION #001 AND 001A ATTACHED**

PAGE 3 OF 3

PLEASE INSPECT PRODUCT PRIOR TO INSTALLING. Carefully review all pre-assembled parts. It will be necessary for the various parts to be re-assembled exactly as shown. **NOTICE:** These instructions do not represent step-by-step directions. They are a product supplement only to be used by a qualified/licensed plumber. We recommend all plumbing fixtures be installed by a professional.

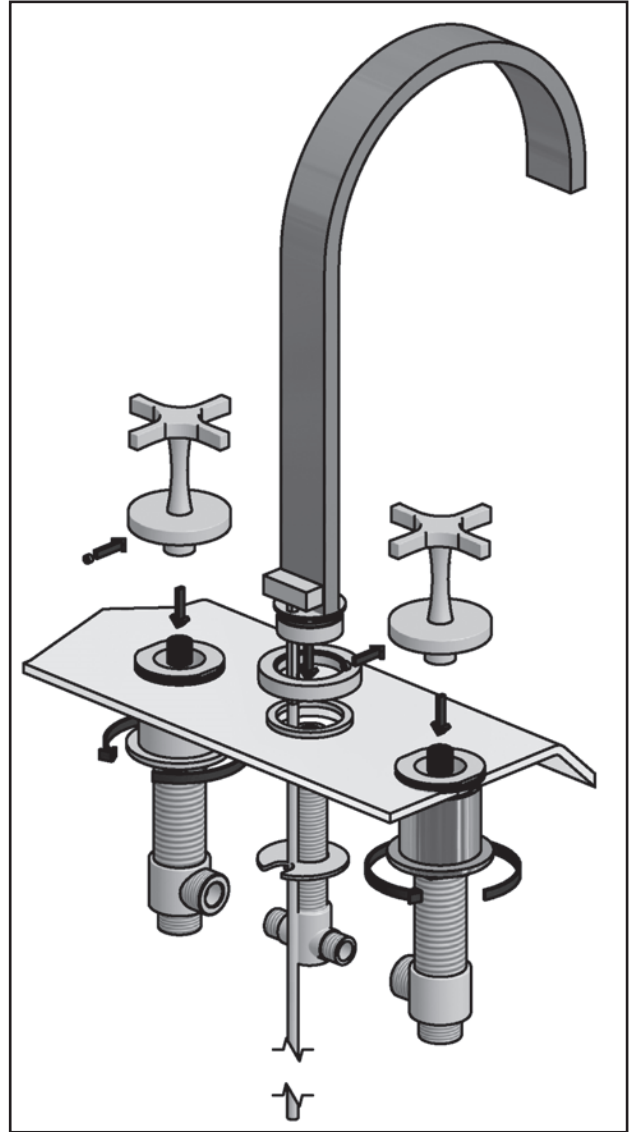
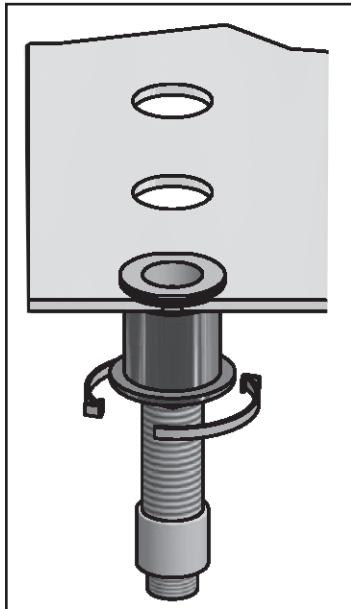
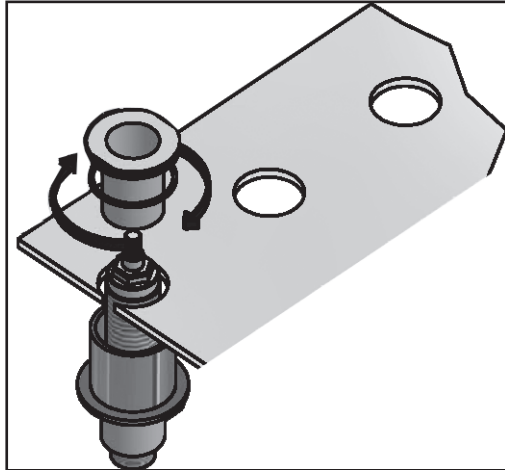

VALVE CARE

Your 1/4 turn ceramic valve will provide you a lifetime of service when cared for properly. The most common valve problem is a result of debris in the water line, such as sand, silt, solder, metal shavings, lime deposits or other foreign particles. Debris can become lodged between the ceramic discs and result in improper functioning of the open and close action of the valve. Particles can even cause cracks in the ceramic discs and render the cartridge useless. For further information, please contact Bluewater Manufacturing Corporation @ 877-890-8006 or fax your request to 877-373-0649

BLUE WATER MANUFACTURING CORPORATION LIMITED PRODUCT WARRANTY

Product/Finish Warranty: Bluewater Manufacturing Corporation warrants that products are free from manufacturing defects in materials and workmanship for five (5) years from date of invoice. In addition, our Finish Warranty provides limited LIFETIME coverage for Chrome & PVD finishes, five (5) years for powder coated finishes & Polished Gold. Living finishes are warranted for workmanship only. If any material proves to be defective after inspection by our company, it will be repaired or replaced at our discretion at no charge. However, no claims for labor, shipping costs, or consequential damages will be accepted.

What we will do: We will restore any product whose finish proves to be defective back to its original finish at no charge during the appropriate warranty period stated above. Proof of purchase must be provided. After the warranty period, **Bluewater Manufacturing Corporation** will refinish any of its faucets at the prevailing appropriate charge.

What you must do: The faucets must be properly installed according to our instructions and specifications and are for residential use only. The faucets cannot be altered in any way. You must maintain and clean the faucets in accordance with the instructions provided with the product. You must use the faucet(s) for residential use only.

How to obtain service: Send your name, address, and telephone number along with a statement describing the nature of the problem and your paid sales slip or other proof of purchase to:

BLUE WATER MANUFACTURING CORPORATION
3231-C Business Park Drive #31
Vista, CA 92081

We will then contact you and take appropriate action. Do not send us any part(s) of your faucet(s) or its various connecting hoses unless we have contacted you and have sent you an approved RGA form. All transportation charges for returned goods must be paid by the customer.

What is not covered: This warranty does not cover the crystal/glass, or porcelain products of any faucet or the drain assembly or aerator on other than the Chrome or PVD finishes. This warranty also does not cover damage caused by accident, alterations, misuse, abuse, normal wear and tear, lime deposits, direct exposure to salty air or corrosive materials, or the color change that takes place with the passage of time, or use in any manner contrary to **Bluewater Manufacturing Corporation's** printed instructions. Cartridge warranties vary. Please call factory for details. In the case of in-the-wall installations, **Bluewater Manufacturing Corporation** will assume no liability if there is no access. **In no event will we be liable for labor of any kind, incidental or consequential damages.** This warranty is extended in lieu of all other expressed or implied warranties, whether oral or written. **Many installation compounds are harmful to brass and metal finishes. The use of any lead-based or acidic curing adhesive, silicone, mastic, or plumber's putty on or near our finished products will void the finish warranty. Use only sealants which are neutral curing and are not reactive with metal and brass finishes.** **Bluewater Manufacturing Corporation** reserves the right to change, modify or alter its products as deemed necessary. This warranty supersedes any other American Faucet & Coatings Corporation warranties, whether oral or written.

Unless otherwise contrary to state law governing the purchase, Bluewater Manufacturing Corporation's liability will not exceed the wholesale price for the Bluewater Manufacturing Corporation product considered defective. This warranty gives you specific legal rights, and you may also have other rights which vary from state to state. Some states do not allow exclusion of incidental or consequential damages, so the above limitation may not apply to you.

LIFETIME WARRANTY ON 1/4 TURN CERAMIC DISC CARTRIDGE

Should the ceramic disc cartridge in your faucet ever fail, **Bluewater Manufacturing Corporation** will replace the failed part free of charge to the original purchaser of the product. Your cost will be a \$7.95 handling and mailing charge. Labor not included. When ordering replacements, denote for widespread or centerset lavatory, Roman Tub, or other. Include age of faucet. (This does not include thermostatic, pressure balance, or diverter cartridges.)

NOTICE

Bluewater Manufacturing Corporation products are IAPMO listed and are tested to ASME A112.18.1M and ASSE 1016, and comply with Section 9 of NSF 61 for basin faucet, bar faucets, and kitchen faucets as required.

Bluewater Manufacturing Corporation