

PLEASE INSPECT PRODUCT PRIOR TO INSTALLING. Carefully review all pre-assembled parts. It will be necessary for the various parts to be re-assembled exactly as shown. **NOTICE:** These instructions do not represent step-by-step directions. They are a product supplement only to be used by a qualified/licensed plumber. We recommend all plumbing fixtures be installed by a professional.

NEW RIBBON SERIES 5-HOLE ROMAN TUB SET

The factory has supplied and "Optional" 5-Way mounting plate as shown in **Diagram #2**.

This plate comes pre-assembled with the (2) rough valves, Quick-connect Spout waterway, 4 Port Deck Diverter and Deckmounting Assembly for the handshower.

The 5-way Mounting plate can be used or not. It can be cut to separate the 4-Port Diverter/Handshower for relocation to a different location around the tub, or used as leveling plate to properly set all rough components even in the installation procedure.

Should the qualified licensed installing plumber decide not to use the mounting plate - take care to re-assemble as shown and not lose any parts.

As shown in **Diagram #2** on the 5-Way mounting plate, the quick-connect comes with the Roman tub 3-Way 3/4 x 3/4 x 3/4 Tee. As noted with Asterisks (*) the installer will supply soft copper for all required waterway connections. The installer should add all necessary teflon tape and confirm water tight - leak proof connections prior to enclosing rough kit in owners selected material i.e. Tile, marble etc.

The factory recommends using licensed and skilled plumbing contractors.



As shown in **Diagram #2**, all trim mounts onto the roughs via a simple set screw interlocking connection in the "V" groove through the decorative trim.
(SEE HANDLE TRIM INSTRUCTIONS.)

Installer should notice that the distance between the mounting plate and the bottom **(SEE DOTTED LINE)** of the connecting sleeves could vary as required by the situation at job site. Certain parts can be cut to allow thin deck application for the HOT and COLD rough valves.
(SEE HANDLE TRIM INSTRUCTIONS)

NOTE: The tub spout connection (3/4" Nipple can be field adjusted as required to fit the other valve height.

It should be noted that the 5-way plate allows the rough to be installed at the same height, but "An Access Panel to this Area is always the best installation practice."

5 HOLE ROMAN TUB SET

DIAGRAM #2

SET SCREW LOCATION

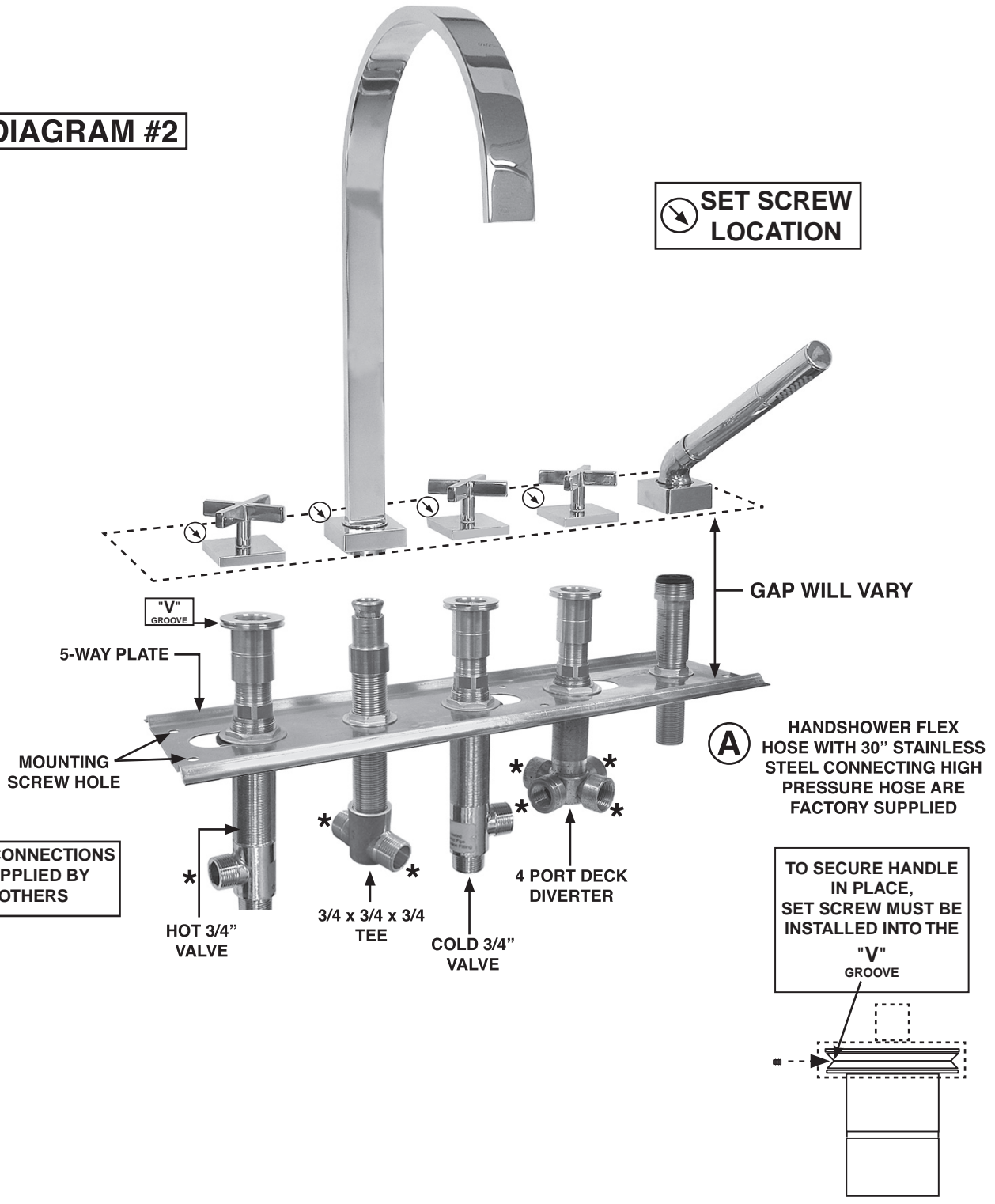

* ALL CONNECTIONS SUPPLIED BY OTHERS

TO SECURE HANDLE IN PLACE, SET SCREW MUST BE INSTALLED INTO THE "V" GROOVE

3/4" ROUGH VALVE
 INSTALLATION GUIDE #004 PAGE 3 OF 4
 ROUGH VALVE

The installation of the rough valve either HOT or COLD side is the same. The following part numbers have adjustment capability as noted. PARTS 7 - 8 - 9 can be field cut as shown in the attached photos.

VALVE INSTALLATION STEPS

STEP #1:

Review the factory pre-assembled valve and handle trim as supplied. Part #'s 1 - 2 - 3 - 4 - 5 and 6 are completely assembled at the factory and should not be dis-assembled. The handle assembly is removed from Deck Mounting Collar #7 by loosening Set Screw #4 with factory supplied Allen Key.

STEP #2:

Remove Deck Mount Collar #7 by unscrewing from Body #10. NOTE: Part #8 - the Stem Extension is loose, be careful not to misplace during dis-assembly procedure.

Next, set aside Collar #7 and Adapter #8. Then insert Valve #10 through bottom of counter/sink and re-assemble #8 Spacer and Collar #7 onto Valve #11.

NOTE: #8 Spacer is optional - Spacer is required for thin tops on sinks only.

Finally rotate Collar #7 securely onto Valve #10 - Make sure Plastic Bottom Nut is secured using proper wrench.

STEP #3:

Drop factory assembled handle 1 through 6 onto Collar #7. Align the assembly as required and tighten with set screw #4.

NOTE: STEM #8 SITS INSIDE COLLAR #7. IT DOES NOT PROTRUDE BEYOND FACE OF COLLAR

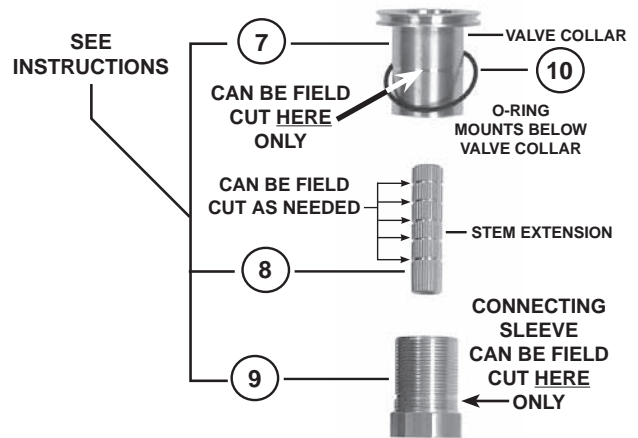
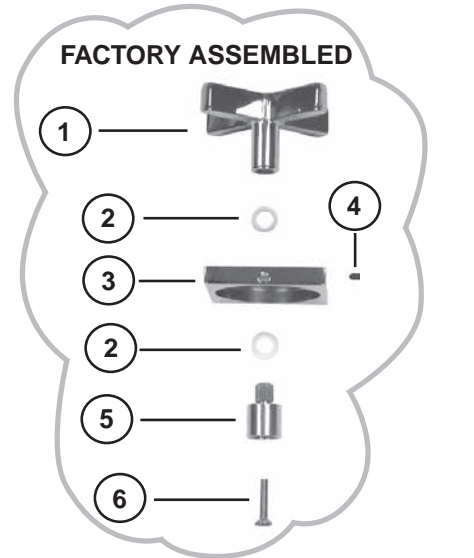

Item	Qty	Description	Part #
1	--	TYPICAL HANDLE (preassembled at factory)	SPECIFY HANDLE
2	1	PLASTIC WASHER	88.01.225
3	1	TYPICAL ESCUTCHEON	SPECIFY ROUND OR SQUARE
4	1	SET SCREW 8-32 x 1/8 CONE	19.01.083
5	1	2-WAY ADAPTER 30 - 20 PT.	88.30.313
6	1	M4 - 20 SCREW	88.30.314
7	1	UNIVERSAL VALVE COLLAR	88.30.316
8	1	STEM EXTENSION 20 - 30 PT.	88.30.319
9	1	XM-24 CONNECTING SLEEVE	88.30.320
10	1	O-RING	88.30.XXX
11	1	20 POINT 3/4" ROUGH VALVE	88.30.XXX

3/4" ROUGH VALVE
 INSTALLATION GUIDE #004 PAGE 4 OF 4

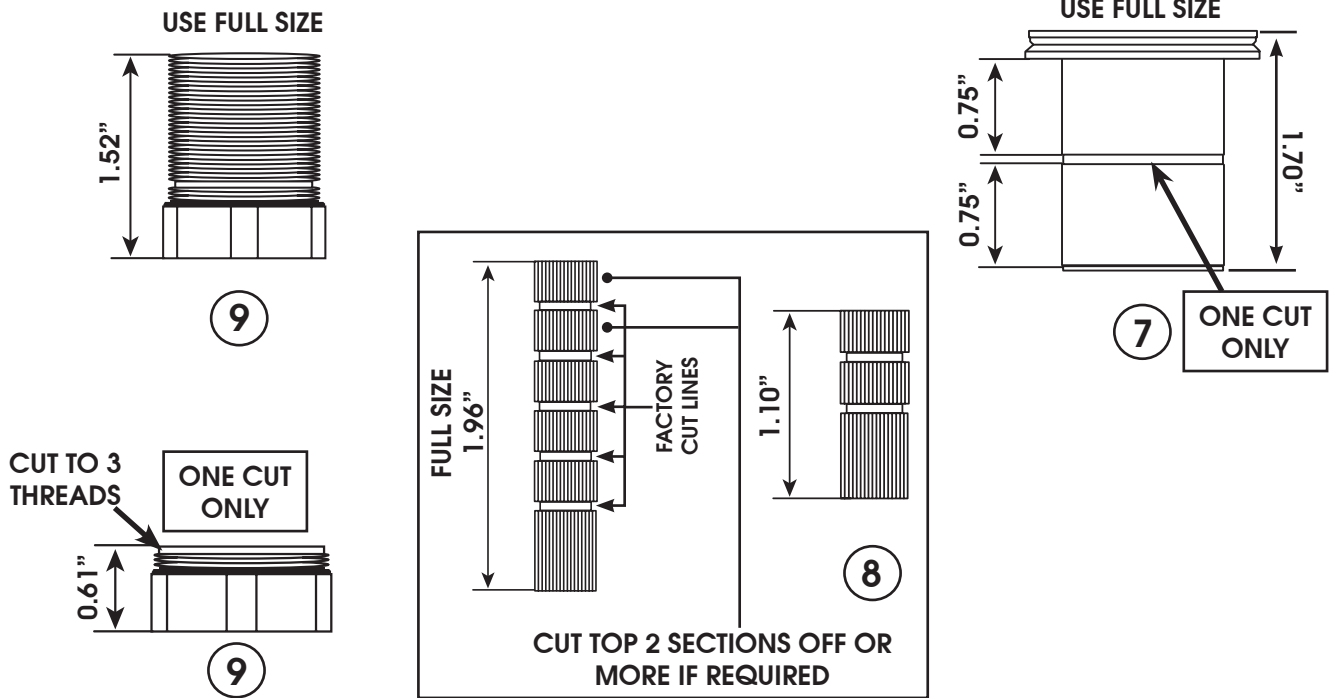

The minimum wall thickness for this extension kit is 1". This does not include the valve body.

Note: Part #9 depicts after cutting at the joint = 3 full threads. Part #7 has been cut in the center - leaving 3/4" to be threaded onto Part #9. Pay close attention to part # 8. There is a top and bottom to the Dual Broached Stem Extension before cutting.

INSTALLER: You must cut the bottom portion off of #8 "Straight" between the cut joints or the handle assembly may sit crooked on your deck. The straighter all cuts, the better the finished installation.

VALVE CARE

Your 1/4 turn ceramic valve will provide you a lifetime of service when cared for properly. The most common valve problem is a result of debris in the water line, such as sand, silt, solder, metal shavings, lime deposits or other foreign particles. Debris can become lodged between the ceramic discs and result in improper functioning of the open and close action of the valve. Particles can even cause cracks in the ceramic discs and render the cartridge useless. For further information, please contact Bluewater Manufacturing Corporation @ 877-890-8006 or fax your request to 877-373-0649

BLUE WATER MANUFACTURING CORPORATION LIMITED PRODUCT WARRANTY

Product/Finish Warranty: Bluewater Manufacturing Corporation warrants that products are free from manufacturing defects in materials and workmanship for five (5) years from date of invoice. In addition, our Finish Warranty provides limited LIFETIME coverage for Chrome & PVD finishes, five (5) years for powder coated finishes & Polished Gold. Living finishes are warranted for workmanship only. If any material proves to be defective after inspection by our company, it will be repaired or replaced at our discretion at no charge. However, no claims for labor, shipping costs, or consequential damages will be accepted.

What we will do: We will restore any product whose finish proves to be defective back to its original finish at no charge during the appropriate warranty period stated above. Proof of purchase must be provided. After the warranty period, **Bluewater Manufacturing Corporation** will refinish any of its faucets at the prevailing appropriate charge.

What you must do: The faucets must be properly installed according to our instructions and specifications and are for residential use only. The faucets cannot be altered in any way. You must maintain and clean the faucets in accordance with the instructions provided with the product. You must use the faucet(s) for residential use only.

How to obtain service: Send your name, address, and telephone number along with a statement describing the nature of the problem and your paid sales slip or other proof of purchase to:

BLUE WATER MANUFACTURING CORPORATION
3231-C Business Park Drive #31
Vista, CA 92081

We will then contact you and take appropriate action. Do not send us any part(s) of your faucet(s) or its various connecting hoses unless we have contacted you and have sent you an approved RGA form. All transportation charges for returned goods must be paid by the customer.

What is not covered: This warranty does not cover the crystal/glass, or porcelain products of any faucet or the drain assembly or aerator on other than the Chrome or PVD finishes. This warranty also does not cover damage caused by accident, alterations, misuse, abuse, normal wear and tear, lime deposits, direct exposure to salty air or corrosive materials, or the color change that takes place with the passage of time, or use in any manner contrary to **Bluewater Manufacturing Corporation's** printed instructions. Cartridge warranties vary. Please call factory for details. In the case of in-the-wall installations, **Bluewater Manufacturing Corporation** will assume no liability if there is no access. **In no event will we be liable for labor of any kind, incidental or consequential damages.** This warranty is extended in lieu of all other expressed or implied warranties, whether oral or written. **Many installation compounds are harmful to brass and metal finishes. The use of any lead-based or acidic curing adhesive, silicone, mastic, or plumber's putty on or near our finished products will void the finish warranty. Use only sealants which are neutral curing and are not reactive with metal and brass finishes.** **Bluewater Manufacturing Corporation** reserves the right to change, modify or alter its products as deemed necessary. This warranty supersedes any other American Faucet & Coatings Corporation warranties, whether oral or written.

*Unless otherwise contrary to state law governing the purchase, **Bluewater Manufacturing Corporation's** liability will not exceed the wholesale price for the **Bluewater Manufacturing Corporation** product considered defective. This warranty gives you specific legal rights, and you may also have other rights which vary from state to state. Some states do not allow exclusion of incidental or consequential damages, so the above limitation may not apply to you.*

LIFETIME WARRANTY ON 1/4 TURN CERAMIC DISC CARTRIDGE

Should the ceramic disc cartridge in your faucet ever fail, **Bluewater Manufacturing Corporation** will replace the failed part free of charge to the original purchaser of the product. Your cost will be a \$7.95 handling and mailing charge. Labor not included. When ordering replacements, denote for widespread or centerset lavatory, Roman Tub, or other. Include age of faucet. (This does not include thermostatic, pressure balance, or diverter cartridges.)

NOTICE

Bluewater Manufacturing Corporation products are IAPMO listed and are tested to ASME A112.18.1M and ASSE 1016, and comply with Section 9 of NSF 61 for basin faucet, bar faucets, and kitchen faucets as required.

Bluewater Manufacturing Corporation