



**REGIONS FOUNDRY
BRASSWORKS LTD.**

**GENERAL THERMOSTATIC INFORMATION FOR HOME
OWNER**

Please read the complete Thermostatic instructions and cautions contained in this booklet before attempting to install the Thermostatic Valve System.

Please be sure the Homeowner is provided the booklet for future reference

FEATURES:

- The thermostatic valve has been in use worldwide for over fifty years.
- Complete serviceability from front of all units.
- 1/2" systems come with 1/4 turn ceramic disc cartridges for both the shut-off valves and volume controls.
- The 1/2" full-flow Thermostatic uses a parafin wax sensitivity cartridge.
- Extension kits are available through your dealer at your local store at an extra charge.
- The 1/2" cartridge constantly monitors temperature and re-adjusts within 2° Fahrenheit of set temperature when supply pressure fluctuates, re-adjustment occurs in less than 2 seconds at the valve body.
- Keep in mind that the distance the shower head or other exit is from the valve will influence how fast you feel the instantaneous correction in the temperature.
- Uniform dials and push-button over-rides are interchangeable on all sizes of valves

INSTALLATION CAUTIONS!

1. State of the art CNC Machining and 1/4 turn ceramic disc cartridges mean precision made product. NO HEAT, NO TORCH ... Shall be applied to the valve assembly.
2. Install male adapters at each port, seal the joint, and then run the required copper lengths to the in-coming water. Solder the copper connection a minimum of 8" away from valve body.
3. Use approved thread sealers at all joints. **DO NOT USE PLUMBERS PUTTY, USE OF ANY CAUSTIC MATERIAL MAY HARM THE FINISH AND OR INTERFERE WITH PROPER FUNCTION OF THE CARTRIDGE.**
4. Prior to installing the thermostatic cartridge, flush all water lines to purge all solder, sand, silt, and debris that have loosened up from the installation process. The lines should be flushed long enough to remove any loosened sediment. Any new additional installation such as a water heater, requires that lines should be flushed again.
5. Failure to flush all water lines properly may damage internal parts. An In-Line waterfilter is recommended to remove harmful sediment, especially if you have well water
6. Inlet check valves are provided with the 1/2" full-flow system. If factory provided check valves are removed for any reason, a qualified plumbing contractor must install check valves upstream of the valve.
7. For proper flow rates and multiple exit installations check with your authorized store for installation assistance. When installing body sprays with 1/2" systems no more than three sprays should be plumbed out of the top outlet for maximum flow in conjunction with a pressure balancing loop.
8. Remember water pressure comes from your local water supplier and can be measured at the source on the street. The valve will not increase water pressure.
9. Pressure or water velocity is not a function of the valve.
10. The water meter for your home should be 25% larger than the water line supply for maximum flow rates from the valve.
11. Do not attempt installation of the product if you do not understand these instructions.
12. Qualified plumbers should be used for all installation procedures.

**FAILURE TO FOLLOW INSTRUCTIONS MAY
CAUSE DAMAGE OR IMPROPER OPERATION AND VOID
THE WARRANTY.**

1. Flush all rough-In piping thoroughly to remove sediment, flux and other debris.
2. Hot and cold inlets are clearly marked. **DO NOT REVERSE CONNECTIONS, THE UNIT WILL NOT WORK CORRECTLY. YOU COULD BE SCALDED!**
3. **DO NOT USE DIRECT HEAT, OR ANY TORCH ON 1/2" ROUGH VALVES.**
4. If unit comes with a black or gray plastic outer ring or cover -- Read directions and be sure you carefully install as directed.
5. Minimum and Maximum finished wall tolerances are clearly marked.
(SEE EXPLODED VIEW OF VALVE)
6. It is extremely important that the rough mixing chamber be free of all debris before installation of the thermostatic cartridge. Read all instructions on boxes, valves and cartridges.
7. **Under no circumstances should the thermostat cartridge be dismantled. Doing so will void any warranty and generally make the cartridge inoperable.**

MAINTENANCE

Regular cleaning each year will extend the life of the cartridge. Never use a screwdriver on any thermostatic cartridge. Never take a thermostatic cartridge apart as you will damage this precision control device. Call your store or the factory for answers to your questions.

NEW 1/2" FULL FLOW THERMOSTATIC INSTALLATION INSTRUCTIONS

- STEP 1** Read the entire booklet first. Verify you have the (7) required installation prints.
- STEP 2** Connect the hot water to the side with red mark (+) and the cold water to the side with the blue mark (-). **SEE CAUTIONS 1-2-3.** Inlets are 3/4" NPT (**SEE PRINT # 4**)
- STEP 3** The in-wall depth of the valve should be installed using **PRINT # 3.** Valve is shipped with maximum extension. Stem extensions can be purchased separately.
- STEP 4** Connect the exit(s) required to 1/2" NPT copper pipe. (**SEE PRINT # 4**) Both the shut-off valves and the volume controls are 1/4 turn ceramic disk cartridges. Any debris in the cartridges may allow exits to drip. If you only need (1) exit, properly plug the 2nd exit. **DO NOT USE HEAT OR TORCH.**
- STEP 5** Open both hex driver inlet ports and pressure test all connections with water. Check for flow and leaks before closing the walls.
- STEP 6** Be sure the hot water heater is connected, clean and operational. Before you calibrate the cartridge, set the hot water to approximately 135° - 140° Fahrenheit. If there is no hot water, you cannot test the system for proper performance.
- STEP 7** The center of the valve is where the thermostatic cartridge is located. The cartridge only controls the mixed water temperature and must be "calibrated" to protect the end user while bathing. Calibration is simple but will take 5 to 7 additional minutes to set the mixed water temperatures to hot and cold limits. You control the temperature range of mixed water through calibration.

Rotate the square (or spline adapter A) tube located on the thermo cartridge (**SEE PRINT # 3**) all the way to the right (**clockwise**) and you have the maximum cold water. Reverse (**counter-clockwise**) and you have the maximum incoming hot water. The set point is up to you. Feel the mixed water at the exit. Let water run for 2 or 3 minutes to confirm comfort level. Install the cover plate. Dial and pointer (**SEE PRINT # 1**) The dial represents a numerical location i.e. 80 where you will place the red pointer to remind you the bather of comfort temperature location selected.

- STEP 8**
HIGH TEMP LIMIT SET POINT TRIM! The combined trim (The Dial Pointer Assembly) has a built-in stop and a manual override which limits the distance the handle will be allowed to turn in the hot direction. If you have calibrated the valve correctly, this CAN prevent children, elderly, and handicapped people from the danger of excessive hot water.

- STEP 9** You are now ready to enjoy your new Regions system.

Regions THERMOSTATIC VALVE

1/2" FULL-FLOW WITH EXIT(S)

TOP HALF DRAWING

EXPLODED VIEW PRINT 1

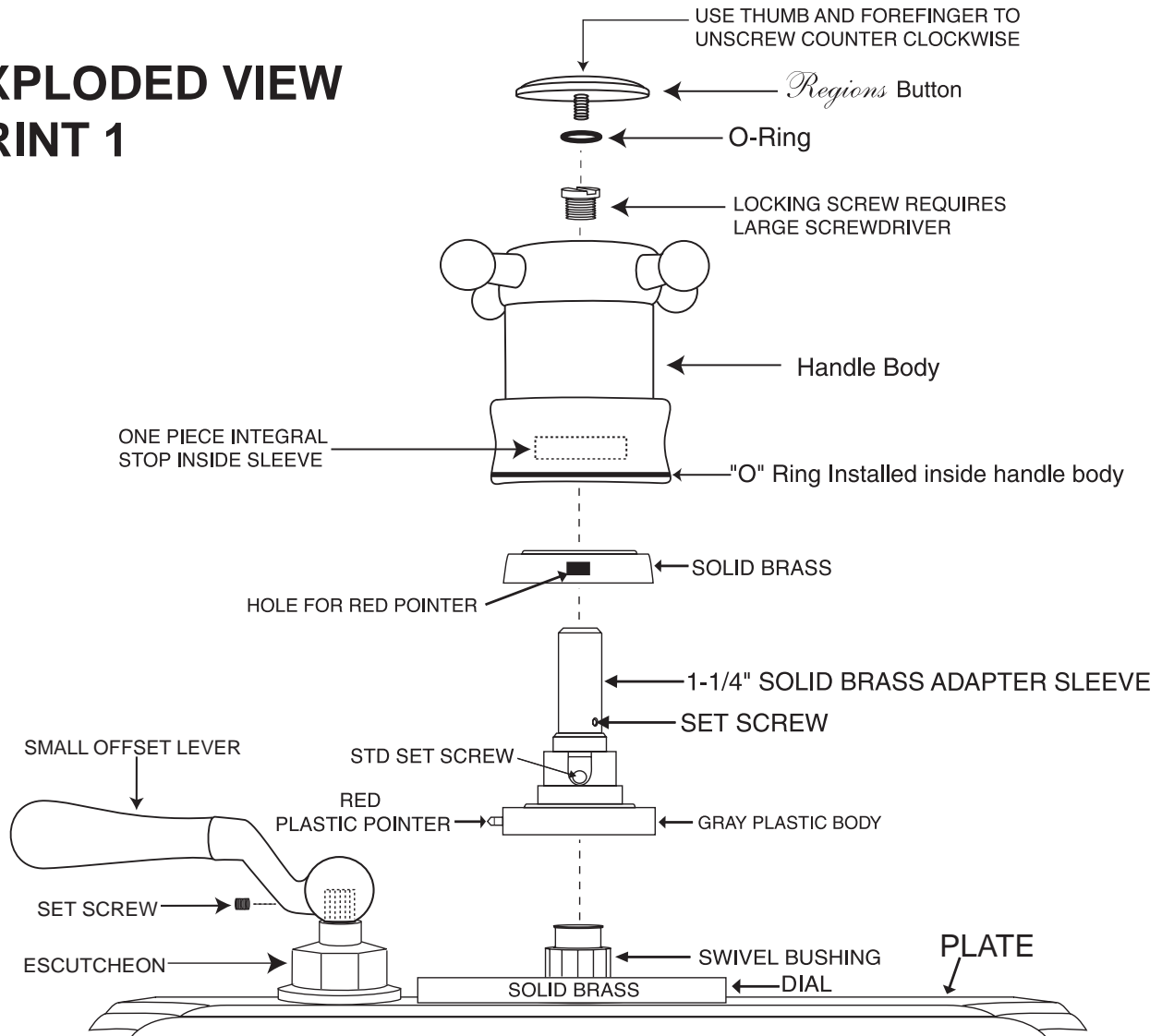

BOTTOM
HALF
SEE
PRINT
2

Regions THERMOSTATIC VALVE

1/2" FULL-FLOW WITH EXIT(S)

BOTTOM HALF DRAWING

EXPLODED VIEW PRINT 2

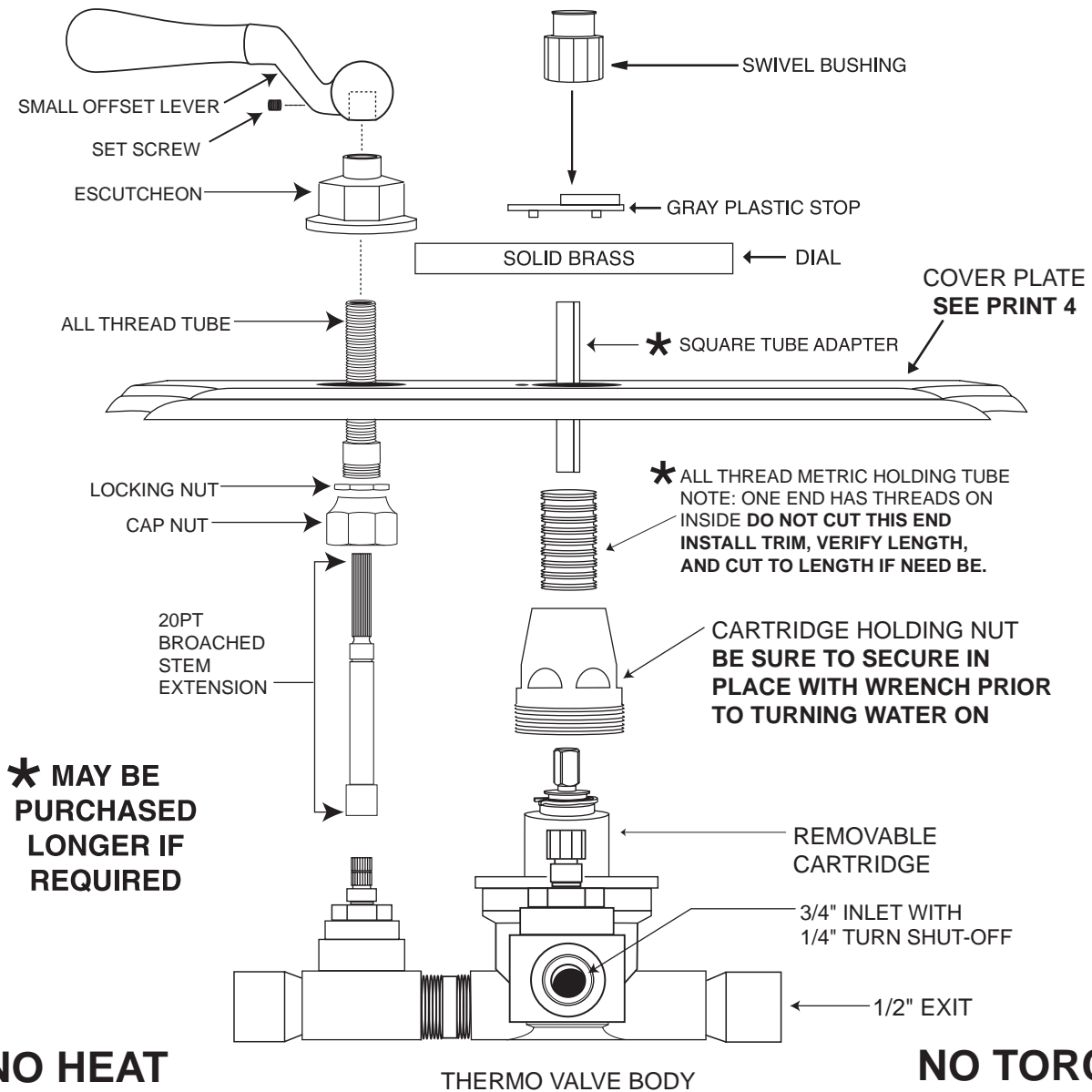

Regions

THERMOSTATIC VALVE

PROFILE VIEW OF INSTALLED ROUGH VALVE ONLY
1/2" FULL FLOW VALVE AVAILABLE WITH SINGLE OR DUAL EXITS

PROFILE VIEW PRINT 3

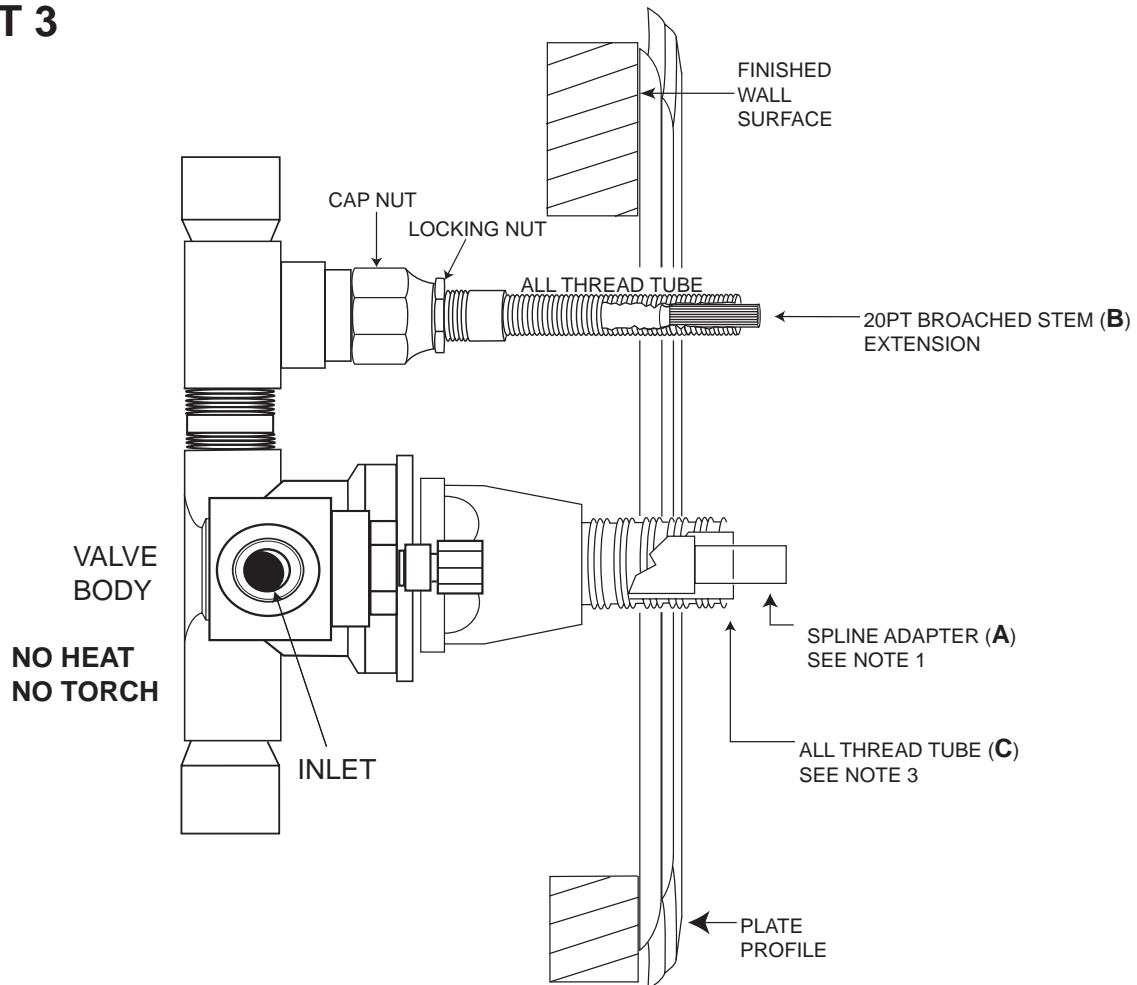

INSTALLER NOTES: THIS VALVE MUST BE INSTALLED AS SHOWN ABOVE

- (1) FROM THE FINISHED WALL TO THE END OF THE SPLINE ADAPTER (A) ALLOW 1-1/2" - PART SHOULD NOT BE CUT - EXTENSIONS ARE AVAILABLE.
- (2) VOLUME CONTROL STEM (B) CAN BE CUT - WE HAVE EXTENSIONS IF VALVE BURIED TOO DEEP.
- (3) THIS IS A SPECIAL ALL-THREAD METRIC TUBE (C) - CAUTION: ONLY ONE END CAN BE CUT - CUT BETWEEN THREADS ONLY.

Bluewater Manufacturing Corporation Phone # 877-890-8006 Fax # 877-373-0649

Regions

THERMOSTATIC VALVE

1/2" FULL FLOW WITH EXIT(S)

**FULL FACE
VIEW PRINT 4**

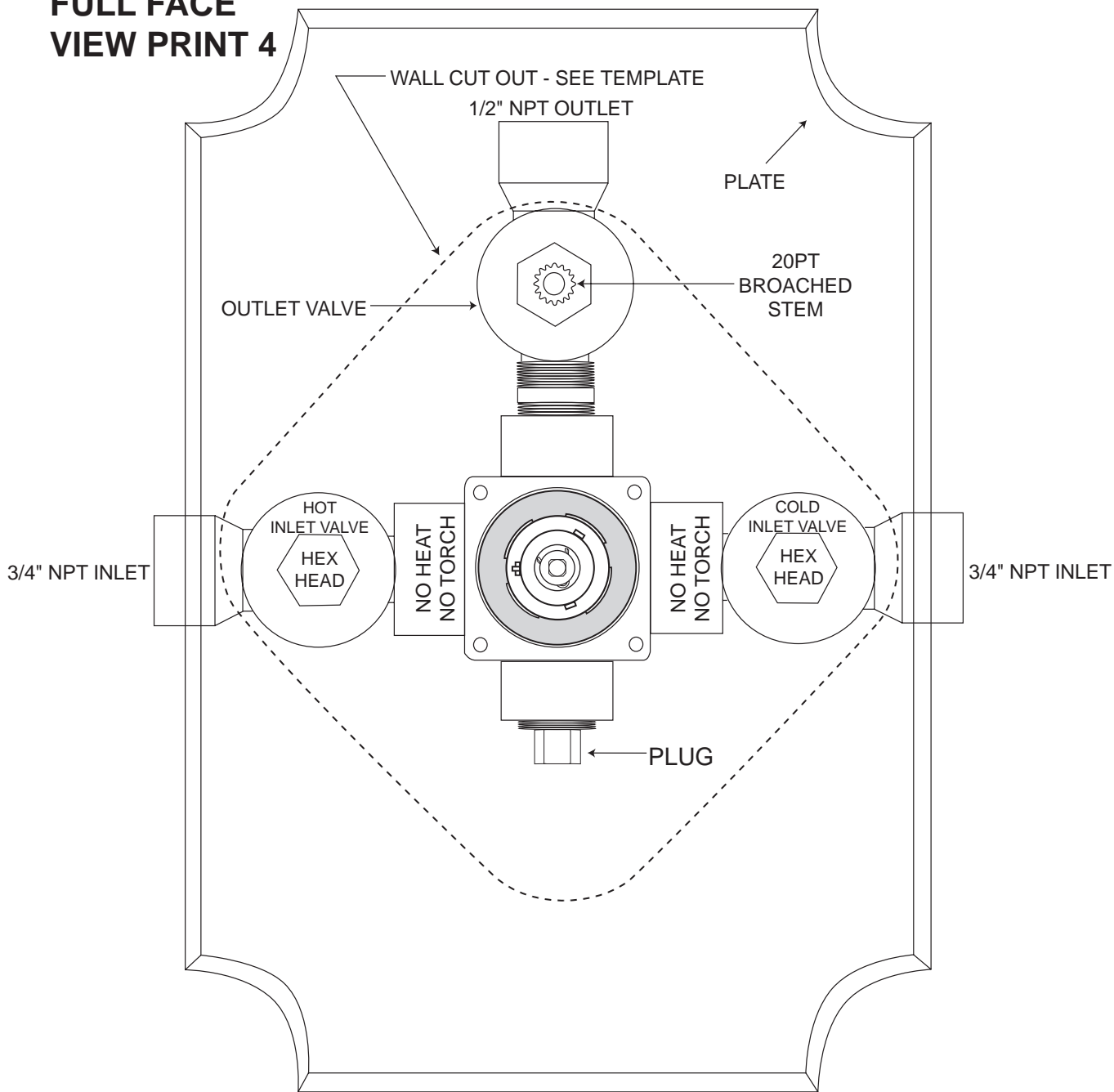

NOT A TEMPLATE

DO NOT SCALE DRAWING

**NO HEAT
NO TORCH**

**FACTORY
TESTED AND
SEALED**

Bluewater Manufacturing Corporation Phone # 877-890-8006 Fax # 877-373-0649

Regions

THERMOSTATIC VALVE
-FULL SCALE (1:1) CUTOUT TEMPLATE
1/2" FULL FLOW WITH DUAL EXITS

PLATE
(SEE NOTE 1)

COVER PLATE
PRINT 5

YOU WILL
NEED TO
EXPAND
THE WALL
CUTOUT
TO THIS
LINE.

ACTUAL MUD PLATE TO SCALE

ACTUAL MUD PLATE TO SCALE

THIS IS A MUD GUARD ONLY
SEE CUTOUT TEMPLATE
FOR INSTALLATION

SEE BLACK GUARD

NOTES:

1. THE SOLID LINE REPRESENTS THE ACTUAL OUTLINE OF THE TRIM PLATE.
2. THE DASHED LINE REPRESENTS THE TYPICAL WALL CUTOUT

THERMOSTATIC 1/2" CARTRIDGE REMOVABLE FROM THE TOP

PRINT

6

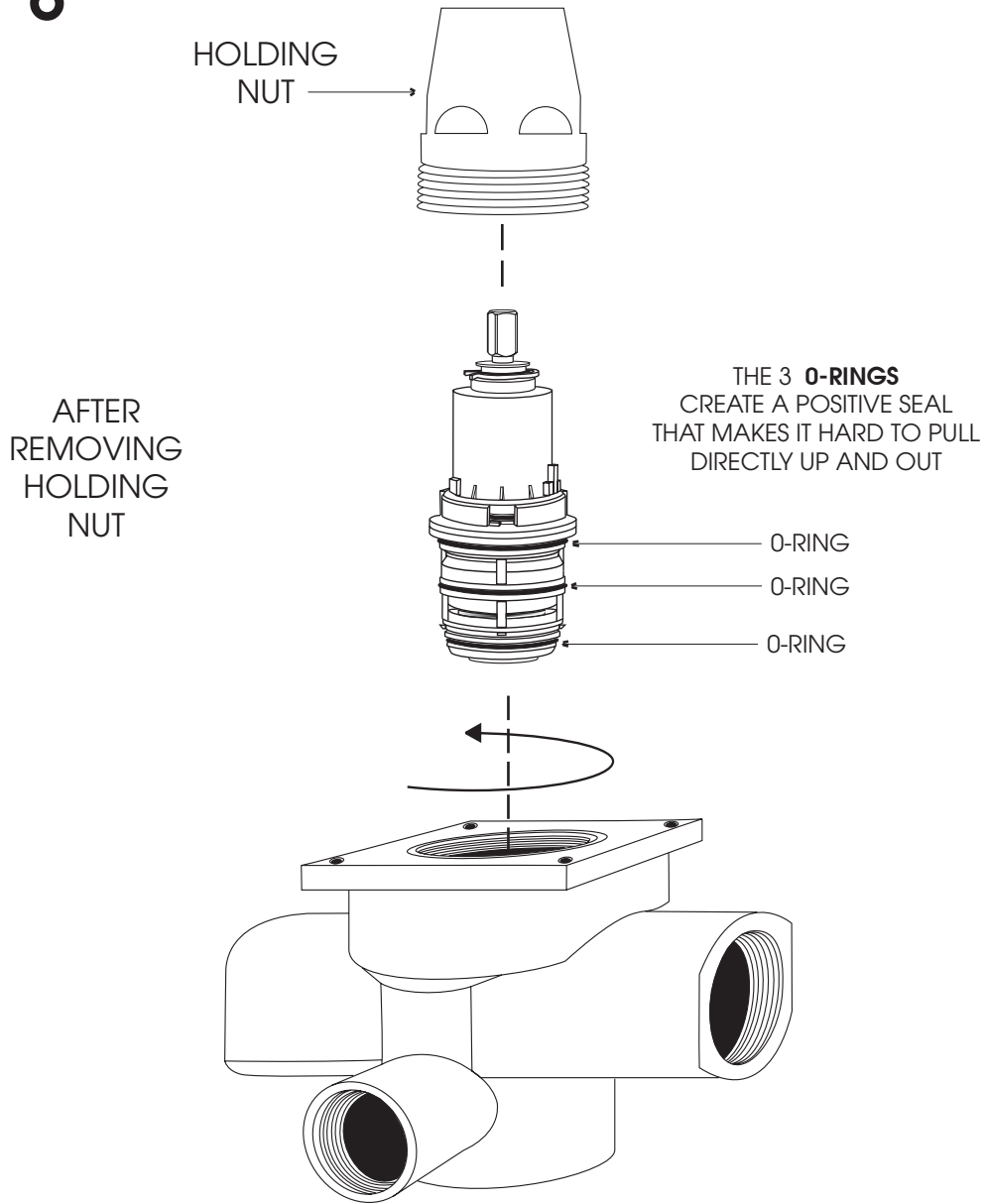

To remove cartridge from body: Rotate cartridge counter clockwise only.

To re-set: (Re-seal - Push straight into body and secure with holding nut)

Regions

NEW THERMOSTATIC 1/2" CARTRIDGE EFFECTIVE 6-15-01

INSTALLATION AND PROPER ALIGNMENT OF CARTRIDGE FOR 2 EXIT BALANCED TEMPERATURE CONTROL

PRINT

8

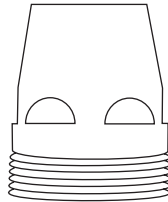

HOLDING NUT

**FIND (1) ONLY
LARGE RAISED
TAB**

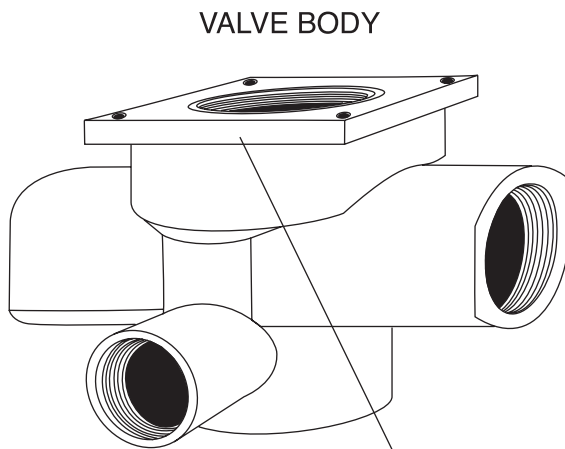
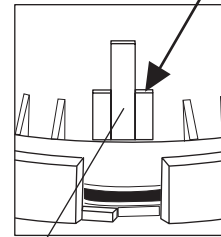

VALVE BODY

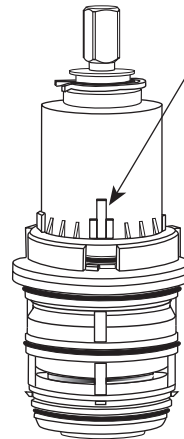

**INITIAL STARTING LOCATION OF
RAISED TAB, FACES CORNER OF
SCREW HOLE POSITION "A"**

**TREAT TOP VIEW OF VALVE
BODY LIKE A "CLOCK"
FOR PROPER POSITIONING OF
RAISED TAB.**

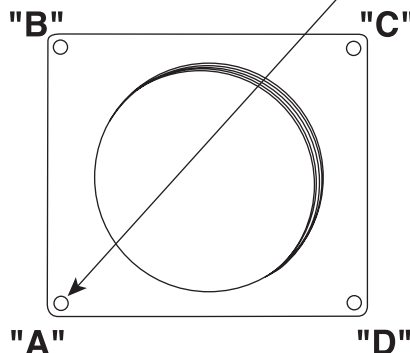

**CARTRIDGE MAY NEED TO BE ROTATED AND
TESTED AT ALL 4 CORNERS FOR PROPER 2
EXIT TEMPERATURE CONTROL ALIGNMENT.**

VALVE CARE

Your 1/4 turn ceramic valve will provide you a lifetime of service when cared for properly. The most common valve problem is a result of debris in the water line, such as sand, silt, solder, metal shavings, lime deposits or other foreign particles. Debris can become lodged between the ceramic discs and result in improper functioning of the open and close action of the valve. Particles can even cause cracks in the ceramic discs and render the cartridge useless. For further information, please contact Bluewater Manufacturing Corporation @ 877-890-8006 or fax your request to 877-373-0649

BLUE WATER MANUFACTURING CORPORATION LIMITED PRODUCT WARRANTY

Product/Finish Warranty: Bluewater Manufacturing Corporation warrants that products are free from manufacturing defects in materials and workmanship for five (5) years from date of invoice. In addition, our Finish Warranty provides limited LIFETIME coverage for Chrome & PVD finishes, five (5) years for powder coated finishes & Polished Gold. Living finishes are warranted for workmanship only. If any material proves to be defective after inspection by our company, it will be repaired or replaced at our discretion at no charge. However, no claims for labor, shipping costs, or consequential damages will be accepted.

What we will do: We will restore any product whose finish proves to be defective back to its original finish at no charge during the appropriate warranty period stated above. Proof of purchase must be provided. After the warranty period, **Bluewater Manufacturing Corporation** will refinish any of its faucets at the prevailing appropriate charge.

What you must do: The faucets must be properly installed according to our instructions and specifications and are for residential use only. The faucets cannot be altered in any way. You must maintain and clean the faucets in accordance with the instructions provided with the product. You must use the faucet(s) for residential use only.

How to obtain service: Send your name, address, and telephone number along with a statement describing the nature of the problem and your paid sales slip or other proof of purchase to:

BLUE WATER MANUFACTURING CORPORATION
3231-C Business Park Drive #31
Vista, CA 92081

We will then contact you and take appropriate action. Do not send us any part(s) of your faucet(s) or its various connecting hoses unless we have contacted you and have sent you an approved RGA form. All transportation charges for returned goods must be paid by the customer.

What is not covered: This warranty does not cover the crystal/glass, or porcelain products of any faucet or the drain assembly or aerator on other than the Chrome or PVD finishes. This warranty also does not cover damage caused by accident, alterations, misuse, abuse, normal wear and tear, lime deposits, direct exposure to salty air or corrosive materials, or the color change that takes place with the passage of time, or use in any manner contrary to **Bluewater Manufacturing Corporation's** printed instructions. Cartridge warranties vary. Please call factory for details. In the case of in-the-wall installations, **Bluewater Manufacturing Corporation** will assume no liability if there is no access. **In no event will we be liable for labor of any kind, incidental or consequential damages.** This warranty is extended in lieu of all other expressed or implied warranties, whether oral or written. **Many installation compounds are harmful to brass and metal finishes. The use of any lead-based or acidic curing adhesive, silicone, mastic, or plumber's putty on or near our finished products will void the finish warranty. Use only sealants which are neutral curing and are not reactive with metal and brass finishes.** **Bluewater Manufacturing Corporation** reserves the right to change, modify or alter its products as deemed necessary. This warranty supersedes any other American Faucet & Coatings Corporation warranties, whether oral or written.

*Unless otherwise contrary to state law governing the purchase, **Bluewater Manufacturing Corporation's** liability will not exceed the wholesale price for the **Bluewater Manufacturing Corporation** product considered defective. This warranty gives you specific legal rights, and you may also have other rights which vary from state to state. Some states do not allow exclusion of incidental or consequential damages, so the above limitation may not apply to you.*

LIFETIME WARRANTY ON 1/4 TURN CERAMIC DISC CARTRIDGE

Should the ceramic disc cartridge in your faucet ever fail, **Bluewater Manufacturing Corporation** will replace the failed part free of charge to the original purchaser of the product. Your cost will be a \$7.95 handling and mailing charge. Labor not included. When ordering replacements, denote for widespread or centerset lavatory, Roman Tub, or other. Include age of faucet. (This does not include thermostatic, pressure balance, or diverter cartridges.)

NOTICE

Bluewater Manufacturing Corporation products are IAPMO listed and are tested to ASME A112.18.1M and ASSE 1016, and comply with Section 9 of NSF 61 for basin faucet, bar faucets, and kitchen faucets as required.